

*Tepe xuny*

0-2201030-0-45		REVISIONS		ZONE		DR		CK		APP		MF	
		DESCRIPTION		NEW RELEASE		TAF		HW		AML			
NO		ER											
1													

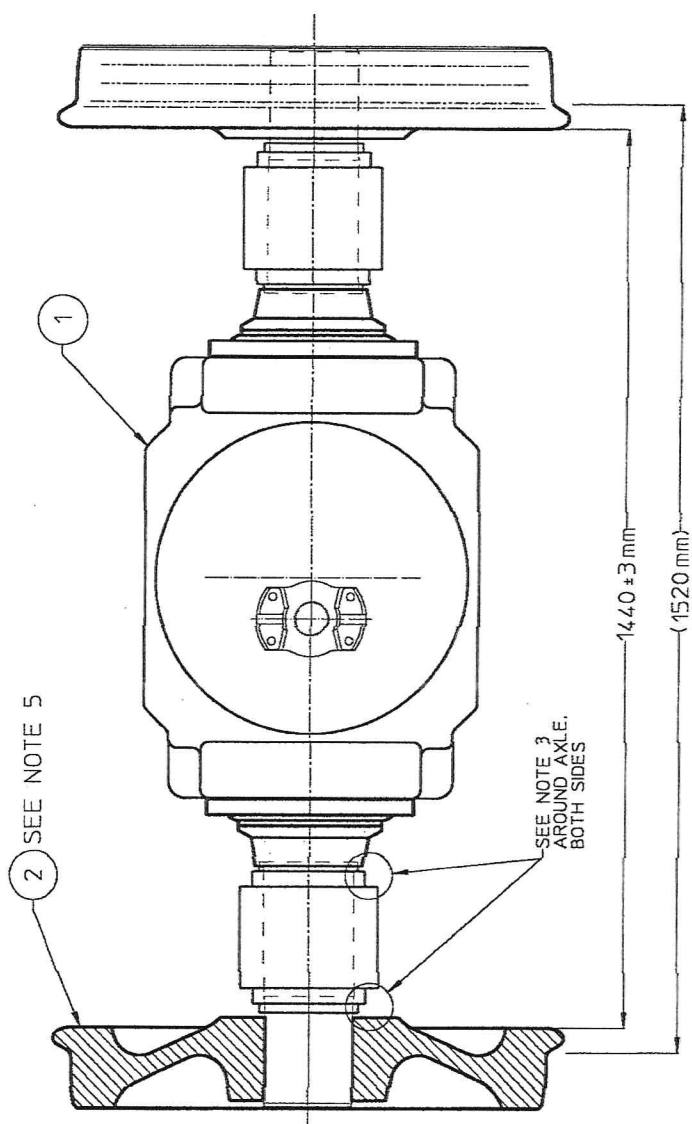

- NOTES:
- 1- CAST WHEELS & FORGED WHEELS CANNOT BE MIXED ON WHEEL & AXLE ASSYS.
  - 2- WHEEL TAPE SIZES TO BE MATCHED EXACTLY FOR EACH WHEEL & AXLE ASSY.
  - 3- APPLY TECTYL SEALER (0-3041001-0-05) LIBERALLY WITH BRUSH, COATING AREAS SHOWN TO SEAL & PREVENT RUST IN BEARINGS.
  - 4- REMOVE & DISCARD BEARING END CAP.
  - 5- HEAT SHRINK WHEELS (ITEM 2) ON AXLE.

FIG ITEM NO.		PART NUMBER		DESCRIPTION AND MATERIAL SIZE (REF ONLY)		CITY	
2		X766874-01-007		WHEEL MACHINING			
1		B5425XAN		AXLE & BEARING ASSY			
		WELDING SPECIFICATION		WHEEL & AXLE ASSY			
		UNLESS OTHERWISE SPECIFIED ALL WELDS SHOULD ADHERE TO FAIRMONT TAMPER WELDING SPECIFICATION NO. 101		DRAWN DATE 23 NOV 98		MACHINE TYPE MARK VI, 1520MM	
		WEIGHT		CHECKED DATE 9 DEC 98		APP-ENG DATE 4 DEC 98	
		30° ANGLE PROJECTION		APP-REG DATE		APP-REG DATE	
		DO NOT SCALE		LAST REV 1186		CHECKED 11-DEC-98	
		SHEET 1 ON 1		DATE		DATE	

**Fairmont Tamper**  
 2401 Edmund Road-Box 20  
 South Corning 29771-0020  
 (803) 822-5160

ALL DIMENSIONS ARE IN INCHES-TOLERANCE UNLESS OTHERWISE SPECIFIED

NOMINAL SIZE RANGE	PLUS OR MINUS	NOMINAL SIZE RANGE	PLUS OR MINUS
OVER TO FRACTION	3 PLACE DECIMAL	OVER TO FRACTION	3 PLACE DECIMAL
- 1 1/4	.01	3/4	.03
1 6 1/2	.02	1 1/16	.05

ANGULAR DIMENSIONS PLUS OR MINUS 1 DEGREE  
 ALL MACHINED SURFACES TO HAVE A SURFACE FINISH OF .25 MICROINCHES UNLESS OTHERWISE SPECIFIED

THIS DOCUMENT CONTAINS PROPRIETARY INFORMATION AND SUCH INFORMATION MAY NOT BE DISCLOSED TO OTHERS WITHOUT THE WRITTEN PERMISSION OF FAIRMONT TAMPER.

УЗЕЛ МОСТА С КОЛЕСАМИ  
 ЧЕРТ. № 0-2201030-0-45  
 РАЗДЕЛ С-5В

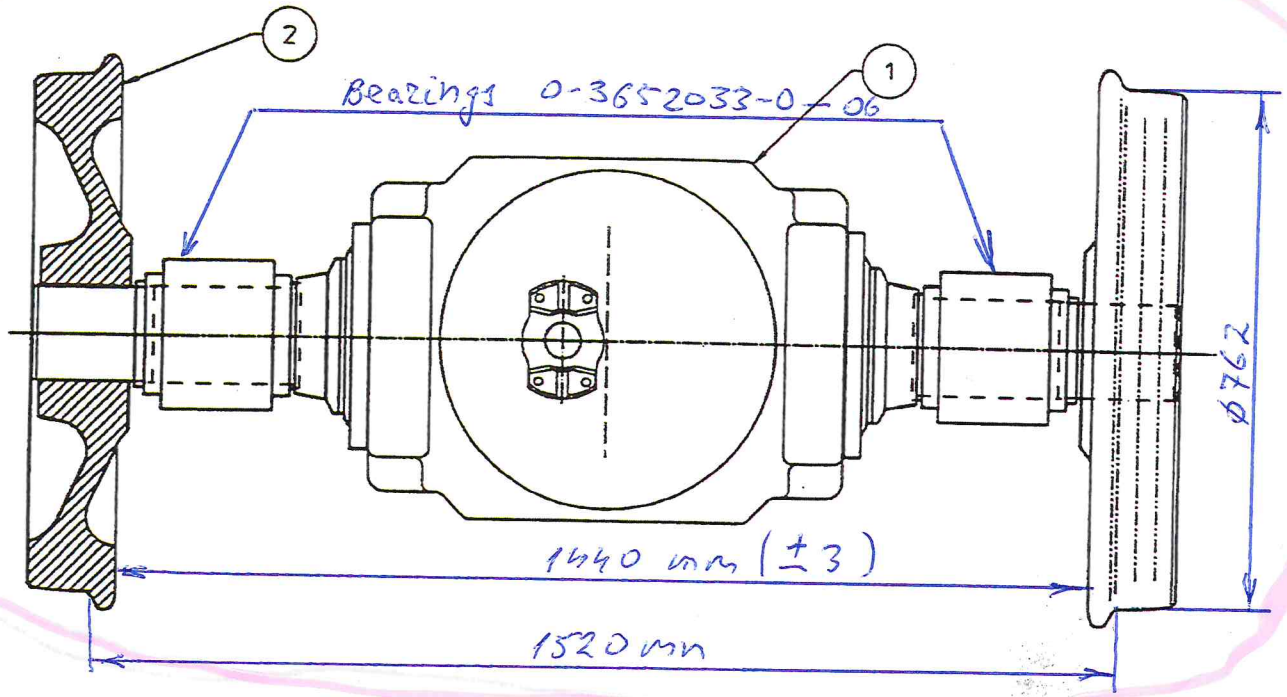

ПОЗ. №	ДЕТ. №	НАИМЕНОВАНИЕ	КОЛ.
2	X766874-01-007	МОДИФИКАЦИЯ КОЛЕСА	2
1	B5425XAN	УЗЕЛ ПОЛУОСИ С ПОДШИПНИКАМИ (СМ. С - 6В)	1