

WHEELS, CARBON STEEL

Specification M-107/M-208

Adopted: 1962; Last Revised: 2011

1.0 SCOPE

These specifications cover one-wear, two-wear, and multiple-wear wrought and cast carbon steel wheels for locomotives and cars—Classes L, A, B, C, and D (heat-treated) wheels used in interchange service. All freight car wheels manufactured for AAR interchange service must be heat-treated and of a low-stress design.

1.1 Class B, C, or D wheels must be used for freight cars in interchange service.

1.2 Class B, C, or D wheels are recommended for use on locomotives.

1.3 For passenger car service, the various classes are intended generally as follows:

Class L—High-speed service with more severe braking conditions than other classes and light wheel loads.

Class A—High-speed service with severe braking conditions, but with moderate wheel loads.

Class B—High-speed service with severe braking conditions and heavier wheel loads.

Class C—(1) Service with light braking conditions and heavy wheel loads.

(2) Service with heavier braking conditions where off-tread brakes are employed.

2.0 DESIGN

2.1 Standard wheel types and tread and flange contours for freight car and locomotive steel wheels shall be as shown in this specification. Interchangeability requirements and tolerances and tread and flange contours for the authorized wheel types are shown in Figs. B.8 through B.14. The interchangeability requirements and tolerances are generally limited to those required to ensure the wheel is compatible with the standard axles, bearings, side frames, and track. In the event that design constraints other than these are shown, the wheel producer may request an exception or change by application, with supporting data, to the AAR Technical Services Division (hereinafter termed AAR). Staff will, in turn, submit the application to the Wheels, Axles, Bearings, and Lubrication (WABL) Working Committee (hereinafter referred to as the “Committee”) for review.

2.2 In the event any company feels there is a need for a wheel type not currently listed, an application, with supporting data, should be made to the AAR, who will obtain the decision of the Committee.

3.0 Authorization for delivery for interchange use of any AAR wheel type must be obtained from the AAR as described in Appendix A.

4.0 Qualification as a manufacturer of wheels for use in AAR interchange service must be in accordance with Appendix B. Qualification is effective until revoked for cause by the Committee. Failure to maintain reasonable quality standards in manufacturing is an example of cause.

5.0 MANUFACTURE

5.1 Discard

A sufficient discard shall be made from the steel used for the manufacture of all steel wheels to ensure freedom from piping and undue segregation.

5.2 Temperature Control

During manufacture of all wheels, necessary care in the regulation of temperature gradients shall be exercised to prevent the development of internal defects or injurious stresses.

6.0 HEAT TREATMENT

6.1 All wheels must be rim-quenched and tempered.

6.2 Rim-Quenching Treatment

All wheels shall be allowed to cool to a temperature below the critical range and uniformly reheated to the proper temperature to refine the grain, and then the rims shall be quenched. Following quenching, the wheels shall be charged into a furnace for tempering to meet the requirements of paragraph 10.0 and subsequently cooled under controlled conditions.

7.0 SHOT PEENING

7.1 Scope

This section covers shot peening of steel wheels to provide improvement in plate fatigue strength.

7.2 Requirements

7.2.1 Shot

The shot shall be SAE No. 550 or larger hardened steel as specified in SAE J827.

7.2.2 Shot Size Control

The peening machines shall be equipped with a separator for continuously removing broken shot. Sufficient new shot shall be added to ensure that a minimum of 85% of No. 550 or larger shot is maintained in the machines at all times.

7.2.3 Peening Intensity

The peening intensity shall be sufficient to produce an average arc height of not less than 0.008 (.0075 +) Almen C on the front plate near the hub fillet and on the back plate near the rim fillet of wheels of the standard design and at back plate hub fillet and front plate rim fillet of the reverse plate design. The area to be peened is defined as the plate area extended approximately one-half of the way into the hub and rim fillet radii on the front and on the back of the wheel.

7.2.3.1 Arc Height Measurement

Measurements of arc height shall be made in accordance with SAE Standards J442 or SAE Recommended Practice J443.

7.2.4 Coverage

The minimum peening time shall be sufficient to ensure that full coverage is attained on the Almen C strip as defined in SAE Recommended Practices J443, Alternate Procedure, or MIL-S-13165 C, Paragraph 6.11

7.2.5 Sequence

Shot peening will be performed on all wheels and after any corrective surface preparation on the plate area. Plate area is defined in paragraph 7.2.3. Peening may be performed prior to inspection.

AAR Manual of Standards and Recommended Practices

Wheels and Axles

M-107/M-208

7.2.6 Portable Peeners

A portable peening device may be used to re-peen small reconditioned areas (no larger than 6 in.²) on wheel plate surfaces, excluding the critical fillet areas (front hub and back rim fillets of wheels of standard designs and back hub and front plate fillets of wheels of reverse plate design). The portable equipment must be capable of peening an Almen C strip to develop the required average arc height of not less than 0.008 in. with a reasonable time of peening. Peening time of wheel plates must be at least as long as the time required to develop the 0.008-in. arc height. The equipment must be tested on an Almen C strip each 8-hour shift that the portable peener is used. A record of the Almen C test results shall be maintained.

7.3 Quality Assurance Provisions

7.3.1 Wheel Surface Condition

The peened appearance of rim and hub shall not be cause for rejection.

7.3.2 Frequency of Test

Arc height determinations shall be made on Almen C strips attached to a test wheel at the beginning and end of each production run but not less than once in each eight operating hours.

7.3.3 Retest

If a test fails to meet the arc height requirements of 0.008 Almen C, two retests will be made. These retests shall be averaged with the first determination. The average shall be not less than 0.008, and no more than one value of the three shall be less than 0.008.

7.3.4 Repeening

When test values fail to meet the provisions of paragraph 7.3.3, corrective action shall be initiated and satisfactory test values secured before proceeding with production peening. If the average Almen value of the unsatisfactory test is 0.006 or 0.007, the last half of the wheels peened prior to the unsatisfactory test (but subsequent to a satisfactory test) shall be repeened with at least 1/2 exposure time. If the average Almen value is less than 0.006, all the wheels peened since the last satisfactory test shall be repeened with full exposure.

8.0 LADLE ANALYSIS

8.1 The steel shall conform to the following chemical requirements:

Table 8.1 Chemical requirements

Element	Ladle Analysis (%)			
	Class L	Class A	Class B	Class C
Carbon	0.47 max.	0.47–0.57	0.57–0.67	0.67–0.77
Manganese	0.60–0.90	0.60–0.90	0.60–0.90	0.60–0.90
Phosphorous	0.030 max.	0.030 max.	0.030 max.	0.030 max.
Sulfur	0.005–0.040	0.005–0.040	0.005–0.040	0.005–0.040
Silicon	0.15–1.00	0.15–1.00	0.15–1.00	0.15–1.00
Residual Elements				
Nickel	0.25 max. ^{a/}	0.25 max. ^{a/}	0.25 max. ^{a/}	0.25 max. ^{a/}
Chromium	0.25 max. ^{a/}	0.25 max. ^{a/}	0.25 max. ^{a/}	0.25 max. ^{a/}
Molybdenum	0.10 max. ^{a/}	0.10 max. ^{a/}	0.10 max. ^{a/}	0.10 max. ^{a/}
Vanadium	0.040 max. ^{a/}	0.040 max. ^{a/}	0.040 max. ^{a/}	0.040 max. ^{a/}
Copper	.35 max.	.35 max.	.35 max.	.35 max.
Aluminum	0.060 max.	0.060 max.	0.060 max.	0.060 max.
Titanium	0.03 max.	0.03 max.	0.03 max.	0.03 max.
Colunbium (niobium)	0.05 max.	0.05 max.	0.05 max.	0.05 max.

^{a/} If the manufacturer chooses to vary from the above limits for nickel, chromium, molybdenum, and vanadium, the following formula must be met:

$$930 - [570 \times \% \text{ carbon}] - [80 \times \% \text{ manganese}] - [20 \times \% \text{ silicon}] - 50 \times \% \text{ chromium}] - [30 \times \% \text{ nickel}] - [20 \times \% \text{ molybdenum} + \% \text{ vanadium}] > 390$$

8.2 An analysis of each heat of steel shall be made by the manufacturer to determine the percentage of the elements specified in paragraph 8.1. This analysis shall be made on a test specimen taken during the pouring of the heat. The chemical composition thus determined, together with such identifying records as may be desired, shall be reported to the purchaser or purchaser's representative and shall conform to the requirements specified in paragraph 8.1.

8.3 Chemical Analysis

Chemical analysis of each heat of steel shall be made by one of the test methods listed below. All analyses should note which method is used for the carbon and/or chemical determinations.

8.3.1 Test Method 1

The carbon determinations should be one of the following test methods:

8.3.1.1 Total carbon by the combustion gravimetric method, ASTM E-350 "Standard Test Methods for Chemical Analysis of Carbon Steel, Low-Alloy Steel, Silicon Electrical Steel, Ingot Iron, and Wrought Iron."

8.3.1.2 Total carbon by the combustion thermal conductivity method, ASTM E-1019 "Standard Test Methods for Determination of Carbon, Sulfur, Nitrogen, Oxygen, and Hydrogen in Steel and in Iron, Nickel, and Cobalt Alloys."

8.3.1.3 Total carbon by combustion, followed by quantitative infrared analysis, ASTM E-1019 "Standard Test Methods for Determination of Carbon, Sulfur, Nitrogen, Oxygen, and Hydrogen in Steel and in Iron, Nickel, and Cobalt Alloys."

AAR Manual of Standards and Recommended Practices

Wheels and Axles

M-107/M-208

8.3.2 Test Method II

ASTM E-415 “Standard Test Method for Optical Emission Vacuum Spectrometric Analysis of Carbon and Low-Alloy Steel.”

8.4 Check Analysis

An analysis may be made by the purchaser from finished wheels selected by the purchaser from each heat in question. For a serviceable wheel, the sample must be obtained from the rim face in a manner that will not impair the usefulness of the wheel. No drilling of the finished wheel plate is permitted. For a broken wheel, the sample may be taken from any part of the wheel mid-radius to tread. When turnings are used, they must be thoroughly mixed together and must be clean and free of oil, scale, and other foreign substances. The check analysis shall not be used in lieu of the ladle analysis to qualify an individual heat.

8.4.1 Sampling Method

When wheel blocks or whole wheels are not available for chemical analysis, the laboratory conducting the chemical analysis shall follow a standard sampling method. This standard method of sampling shall be ASTM E-1806, “Standard Practice for Sampling Steel and Iron for Determination of Chemical Composition.” Then use either ASTM E-350, E-1019, or ASTM E-415 as specified in paragraph 8.3 for chemical analysis of the sample.

8.4.2 Check Analysis—Permitted Variance from Specified Ranges

The following tolerances are permitted between the check analysis and the specified chemical limits:

Table 8.2 Check analysis variation from ladle analysis

Carbon ±0.04	Manganese ±0.03	Phosphorus +0.008	Sulfur ±0.005	Silicon ±0.05
-----------------	--------------------	----------------------	------------------	------------------

Nickel +0.03	Chromium +0.03'	Molybdenum +0.01	Vanadium +0.01	Copper +0.03	Aluminum +0.01	Titanium +0.05	Columbium +0.02
-----------------	--------------------	---------------------	-------------------	-----------------	-------------------	-------------------	--------------------

9.0 INTERIOR CONDITION/MICROCLEANLINESS STANDARDS

9.1 Sample Frequency

The metallurgical cleanliness of the wheel steel shall be determined from samples taken from randomly selected finished wheels representing the heat. A minimum of one 33-in. wheel and one 36-in. wheel of different heats produced quarterly per facility shall be tested.

- Facilities that produce only 33-in. or 36-in. wheels shall test two wheels of different heats quarterly.
- Facilities producing different size wheels to AAR specifications during a quarter shall test at least two wheels of different heats during the subject quarter.
- Facilities not producing wheels to AAR specifications during four successive quarters shall, at a minimum, test at least two wheels from a heat specially produced to AAR specifications for the scheduled facility certification continuation inspection once a year.

The purchaser reserves the right to more frequent testing should it be deemed necessary by mutual agreement between the purchaser and producer.

9.2 Sample Size and Location

A minimum of six samples shall be taken from each wheel tested approximately equidistant around the circumference of the wheel. Each sample shall be 7/8 in. long in the circumferential direction (the rolling direction), 3/4 in. wide in the axial direction (the rim width), and 1/2 in. thick in the radial direction (the rim thickness). The circumferential surface for microcleanliness evaluation shall be located 1/2 in. below the wheel tread and 2 1/2 in. to 3 1/4 in. from the back rim face. Dimension tolerances are ±1/8 in.

9.3 Sample Preparation and Evaluation

9.3.1 Each 7/8 in. × 3/4 in. × 1/2 in. sample shall be carefully prepared and evaluated to ASTM Standard Practice E1245. The flicker method shall be used to establish the correct setting of the gray-level threshold limits.

9.3.2 The total area evaluated for each sample shall be not less than 1/4 in.² or 161 mm². All inclusions greater than 2.5 μm, regardless of inclusions being exogenous or indigenous in the plane of polish, shall be counted. The WABL Committee must approve alternates to this method.

9.3.3 Effective January 1, 2008, average and worst field area percentage oxides, voids, and sulfides will be recorded. The AAR shall be advised quarterly when the six samples representative of the heat tested average more than 0.100% oxide plus voids; or the worst field area percentage of any one sample is more than 0.750% oxide plus voids; or 0.750% sulfides. If AAR is advised in two successive quarters, the provisions of *AAR Manual of Standards and Recommended Practices*, Administrative Standards, Standard S-060, paragraph 5.3, shall apply. In such cases, a special facility inspection may be required to demonstrate that the root cause has been identified and addressed.

9.3.4 Each sample shall be permanently marked according to heat and wheels represented and retained for a period of 1 year after the wheels are shipped. Records of test results shall be kept for 10 years after the wheels are shipped. Inspection results will be available for review by the AAR or other interested parties. AAR or other interested parties may have the test samples evaluated by other accredited laboratories at their expense.

10.0 BRINELL HARDNESS

10.1 The hardness of the rim, when measured in accordance with the requirements of paragraph 10.2, shall show the following values:

Table 10.1 Brinell hardness of rim

Class	Minimum Hardness	Maximum Hardness
L	197 BHN	277 BHN
A	255 BHN	321 BHN
B	302 BHN	341 BHN
C	321 BHN	363 BHN
D	341 BHN	415 BHN

Note: Class D alloy steel wheels must meet all chemical requirements for Class C wheels and have approval of the AAR WABL Committee.

10.2 Method of Measurement

Measurement must be made in accordance with ASTM E-10 (latest revision) on the front face of the rim with the edge of the impression not less than 3/16 in. from the radius joining face and tread. Before making the impression, any decarburized metal shall be removed from the front face of the rim at the point chosen for measurement. The surface of the wheel rim shall be properly prepared to permit accurate determination of hardness.

IMPLEMENTED 03/2012

AAR Manual of Standards and Recommended Practices
Wheels and Axles

M-107/M-208

11.0 NUMBER OF TESTS

11.1 Where continuous heat-treating furnaces are used, BHN measurements shall be made on 10% of the wheels from each heat. Where batch-type heat-treating furnaces are used, BHN measurements shall be made on 10% of the wheels from each heat-treatment lot. For batch-type heat-treating, at least one wheel from each heat in the heat-treatment lot must be tested. For either heat-treatment process, BHN measurements must be made on a minimum of one wheel in a heat or heat-treatment lot of 10 or less, and on a minimum of 2 wheels in a heat or heat-treatment lot of 11 to 20.

11.2 If all the wheels tested meet the requirements of paragraph 10.0, all of the wheels represented shall be accepted.

11.3 If any wheel tested fails to meet the requirements of paragraph 10.0, it shall be checked by making two additional hardness measurements, one on each side of the point first measured and each approximately 1 in. from that point. If both of these check measurements meet the requirements of paragraph 10.0, the wheel shall be considered to have met the requirements of paragraph 10.0.

11.4 When continuous heat-treating furnaces are used, should any of the wheels tested fail on check test to meet the requirements of paragraph 10.0, the manufacturer may test for individual hardness measurements all of the wheels of that heat in the lot submitted for inspection, and those meeting the requirements of paragraph 10.0 shall be accepted. Where batch heat-treating furnaces are used, should any of the wheels tested fail on check test to meet the requirements of paragraph 10.0, the manufacturer may test all of the wheels in the heat-treatment lot for individual hardness measurement, and those meeting the requirements of paragraph 10.0 shall be accepted.

11.5 On new wheel designs or existing designs to which process changes are made, hardness gradient tests shall be performed on a minimum of one wheel from each of the first five heats of steel produced. The hardness shall be taken per Fig. 11.1 utilizing an approved hardness test machine. Values shall meet the requirements as shown in Table 11.1.

Table 11.1 Acceptable hardness ranges

Class	Minimum	Maximum
B	285 HB	341 HB
	28 Rc	40 Rc
C	301 HB	363 HB
	30 Rc	42 Rc
D	321 HB	415 HB
	32 Rc	44 Rc

If values do not meet the requirements in Table 11.1, an additional five wheels from five heats shall be tested. All five wheels must meet the requirements in Table 11.1. If one or more wheels fail to meet the requirements in Table 11.1, testing per paragraph 11.5 shall be repeated after a process and/or design change is made. All wheels from heats that have a test wheel that failed to meet the requirements in Table 11.1 shall be reheat-treated, and one wheel from the heat shall be tested. If this wheel fails to meet the requirements in Table 11.1, all wheels from the heat shall be scrapped. Only one reheat treatment shall be allowed.

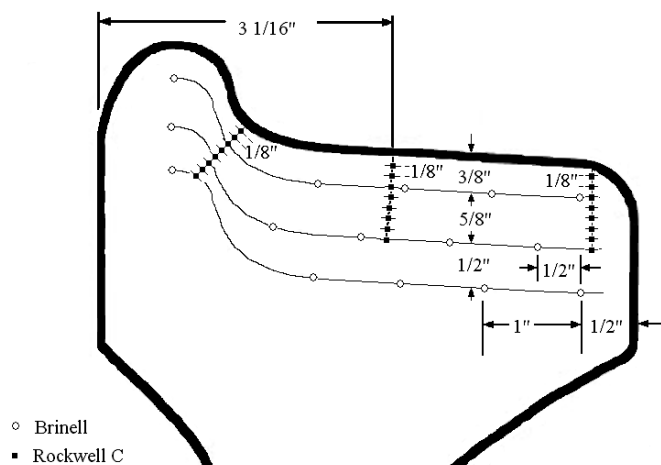

Fig. 11.1 Hardness mapping locations

12.0 RETREATMENT

Any wheel failing to meet the requirements of paragraph 10.0 may be retreated and tested in accordance with paragraph 11.0.

13.0 MATING

Wheels shall be measured and marked to the lower tape number until the next graduation is reached. Wheels shall be shipped in pairs of the same measured tape size.

14.0 GAUGES

The gauges and tapes shall conform to and be used as required by the standards of the AAR Technical Services Division Alternate tape gauging will meet or exceed the AAR measurement standard for taping wheels. The repeatability and reproducibility of all alternate gauges must be demonstrated.

15.0 PERMISSIBLE VARIATIONS

15.1 The wheels shall conform to the dimensions with tolerances as specified in Figs. B.8, B.9, B.11, and B.12 for freight car wheels and in Figs. B.8 and B.10 for locomotive wheels.

15.2 Where Figs. B.9 and B.10 allow a certain percentage of the wheels to vary from standard dimensions for tape size by a given amount, the percentage of such wheels shipped by any manufacturer shall not exceed this percentage during a calendar year. No individual purchaser may receive more than this percentage of his daily shipments of such wheels except by agreement with the manufacturer.

AAR Manual of Standards and Recommended Practices

Wheels and Axles

M-107/M-208

16.0 FINISH

16.1 Wheels shall be rough bored and shall not have black spots in the rough bore. Front hub face of wheels (1-W, 2-W, and MW) shall be parallel to the plane of the vertical reference line and may be smooth forged, cast, or machined. The back hub face may be smooth forged, cast, or machined.

16.2 The contour of tread and flange shall be as shown in Figs. B.11, B.12, or B.13 as applicable. Wrought steel wheels must be machined and finished smooth without excessive tool chatters. Cast steel wheels shall be as cast, machined, or ground, at the option of the manufacturer. Minimum and maximum flange thickness, height, and throat radii gauges shown in Standards S-661 and S-662 shall be used to check proper profile. Wheels that do not meet the criteria must be scrapped or recontoured.

16.3 Wheels must be free of all condemnable in-service defects. As-produced surfaces must be free from abrupt changes in surface contours. Spot grinding or machining to remove surface defects must not exceed a depth of 1/8 in. (0.125 in.; 3.2 mm). Sectional properties must meet all dimensional requirements following repair of surface defects. Repaired surfaces must have a maximum surface roughness of 500 μ in. prior to final shot peening. Repaired surfaces must provide a uniform transition to the as-produced surfaces.

16.4 Wheels shall not be covered with any substance to such an extent as to hide defects.

16.5 Wheel profile is to be checked using wide flange profile gauge shown in Fig. B.14. There will be no more than 1/32-in. variation from the profile.

17.0 MARKING

17.1 Identification markings shall be legibly stamped as shown in Figs. B.4 or B.5. Wheels for freight service must be hot stamped or cold stamped on the back hub face. If any stamped characters are missing or illegible, these shall be replaced by cold stamping in the proper place in the marking sequence. Passenger car wheels may be hot stamped or cold stamped on front or back (as specified by purchaser) hub face. When ordered, locomotive wheels may be hot or cold stamped on the back rim face; or hot or cold stamped on the front hub face; or hot or cold stamped on the back hub face providing finish machining will completely remove the markings on the back hub face. Locomotive wheels that are to receive final hub machining by the purchaser may be ordered with markings paint stenciled on the wheel plate. After final machining, the purchaser will cold stamp the markings on the front hub face. For wheels having raised cast-on markings, the markings shall be legible characters and be as shown in Fig. B.7. For all wheels, stamping should be centered approximately on the hub. No wheel manufactured after May 1, 2009, may be bored and applied with any portion of the wheel manufacturer's hub stamp closer than 1/8 in. from the inner hub diameter and no closer than 1/8 in. from the outer hub diameter. No wheel manufactured before May 1, 2009, may be bored and applied with any portion of the wheel manufacturer's hub stamp breaking over the edge of the inner or outer hub diameter.

17.2 The tape size of all wheels shall be paint stencilled on back plates in characters at least 1 in. high. An "H" shall also be paint stencilled on the front plate at least 1 in. in height on those wheels of curved plate, heat-treated configuration. Stencil paint must be white and have a minimum service life of 1 year.

17.3 Effective April 1, 2012, bar code labels must be affixed to all new freight car wheels in accordance with the *Manual of Standards and Recommended Practices*, Section L, Standard S-920.

IMPLEMENTED 01/2012

18.0 INSPECTION

18.1 The inspector representing the purchaser shall have free entry, at all times while the work on the purchaser's contract is being performed, to all parts of the manufacturer's works that concern the manufacture of wheels ordered. The manufacturer shall afford the inspector, free of charge, all reasonable facilities and necessary assistance to satisfy the inspector that the wheels are being furnished in accordance with these specifications. Internal defects are usually detected by ultrasonic testing. Such test shall be used in the manufacture of all wheels. The method to be followed and the equipment to be used shall comply with the requirements as shown in paragraph 18.4. Tests and inspection shall be made at the place of manufacture prior to shipment, unless otherwise specified.

18.2 The purchaser may make tests to govern the acceptance or rejection of the wheels in purchaser's own laboratory or elsewhere. Such tests shall be made at the expense of the purchaser.

18.3 All tests and inspections shall be so conducted so as not to interfere unnecessarily with the operation of the works.

18.4 Ultrasonic Inspection

For detecting internal discontinuities in the rim of all steel wheels, ultrasonic inspection shall be made by following either the procedures shown below or an AAR-approved equivalent. Equipment used in these procedures shall comply with the following requirements.

Each manufacturer shall maintain a documented test method and procedures for ultrasonic inspection of all railroad wheels manufactured under this specification.

18.4.1 Equipment

18.4.1.1 The instrument shall have a pulse echo receiver and shall operate at frequencies of 2 to 5 MHz required for the test method and type of equipment used.

18.4.1.2 The transducers shall be of the type whose composition and dimensions are appropriate for the test method used.

18.4.1.3 The ultrasonic inspection shall be performed with an automated scanning system. An automatic flaw alarm system shall be used in conjunction with the ultrasonic instrumentation.

18.4.1.4 A suitable couplant shall be used between the test surface and the transducer. The couplant shall be free of air bubbles. Rust inhibitors, softeners, and wetting agents may be added to the couplant.

18.4.2 Time of Inspection

Inspection shall be performed after final thermal processing.

AAR Manual of Standards and Recommended Practices

Wheels and Axles

M-107/M-208

18.4.3 Calibration

18.4.3.1 Calibration shall be conducted using a reference standard of a wheel or portion of a wheel rim containing simulated defects or other AAR-approved procedure. The instrument sensitivity level should be adjusted to produce an approximate full-scale reflection from the reference standards of paragraphs 18.4.3.2, 18.4.3.3, 18.4.3.4, and 18.4.3.5.

18.4.3.2 For axial testing of all wheels, the reference standard shall be a 1/8-in.-diameter flat-bottom hole generated perpendicular to the rim face and to a depth of 1 1/2 in. ($\pm 1/16$ in.) at the mid-thickness of the rim. See Fig. B.1

18.4.3.3 For radial testing, the reference standard shall be a 1/8-in.-diameter flat-bottom hole generated from the inside diameter of the rim perpendicular to the tread surface, and shall be a minimum of 1 1/4 in. from the tread surface. See Fig. B.2.

18.4.3.4 A distance amplitude correction (DAC) shall be used for axial and radial testing of wheels. To ensure detection, the DAC will be generated for each testing direction in the following manner.

Holes shall not be located close to each other so as to impede the response from each hole individually.

18.4.3.4.1 Axial

As a minimum, two additional 1/8-in.-diameter flat-bottom holes shall be generated at whatever depth the manufacturer chooses. The creation of the DAC shall be accomplished using the reference standard and the response(s) from additional holes. Typical depths for the three holes could be 1 1/2, 2 1/2, and 3 1/2 in. All holes should be generated from the front or back rim face. See Fig. B.1. Individual depth standards shall be permitted.

18.4.3.4.2 Radial

To facilitate creation of a DAC, as a minimum, one additional 1/8-in.-diameter flat-bottom hole shall be generated in one-wear and two-wear wheels, and, as a minimum, two additional 1/8-in.-diameter flat-bottom holes shall be generated in multi-wear wheels. Calibration shall be accomplished using the reference standard, and the response(s) from the additional holes shall be used to create the DAC. Table B.1 shows the depth of reference standard holes for the different wheel types. See Fig. B.2. Individual depth standards shall be permitted.

18.4.3.5 Alternate calibration standards may be used when authorized by the AAR WABL Committee. Manufacturer shall document and demonstrate the correlation between the 1/8-in.-diameter flat-bottom hole and the proposed alternate standard.

18.4.3.6 An alternate method for axial testing of cast steel wheels is to use loss of back reflection. The reference standard shall be a 3/8-in.-diameter concave bottom hole generated to a depth of 1/8 in. at the front rim face. See Fig. B.3.

18.4.3.7 Reference standards for the inspection of wheels shall be made from rim-treated wheel steel made by the same process as the wheels being inspected, i.e., wrought or cast. Reference standard need not be the same AAR design as the wheels being inspected.

18.4.3.8 Recalibration

Conduct ultrasonic calibration to ensure system conformance to required specifications. Check the ultrasonic system and calibration of the instrument per documented procedures using a calibration standard when any of the following occurs:

- Damage to any part of the ultrasonic system
- Change in transducers, cables, and other accessories
- Loss of power or equipment malfunction
- Whenever ultrasonic instrumentation is first turned on

18.4.3.9 System Verification and Test Results Validation

18.4.3.9.1 Conduct ultrasonic calibration checks to ensure system conformance to required specifications.

18.4.3.9.2 System calibration shall be verified per documented procedures using a calibration standard at least every 8 hours of operation. If the results from system verification are outside of system tolerance, assessment of previous inspections must be made and appropriate action taken. Action taken shall be supported by wheel reinspection data.

18.4.3.9.3 Records shall be maintained of system calibration and system verification.

18.4.4 Scanning

18.4.4.1 Wheels shall be inspected axially from either the front or back rim face and radially from the tread surface.

18.4.4.2 One or more transducers shall be designed and located to give maximum volumetric coverage of the rim cross-section both radially and axially.

Each manufacturer shall ensure optimum volumetric coverage for the test method and manufacturing process. Optimization of coverage is verified by using supplemental reference standard holes located in different areas of the rim, as shown in Figs. B.3.1 and B.3.2.

18.4.4.3 Scanning speed shall permit detection of reference standards at calibration level.

18.4.5 Rejection

18.4.5.1 Any wheel with a flaw indication equal to or larger than 25% of the reference standard at the estimated discontinuity depth shall be cause for rejection.

18.4.5.2 Any indication from discontinuity giving a loss of back reflection equal to or greater than the reference standard (covered in paragraph 18.4.3.6) during axial scanning shall be cause for rejection.

18.4.5.3 Ultrasonic indications that result from wheel geometry or spurious electrical signals shall not be valid cause for rejection.

18.4.5.4 The final disposition of rejectable wheel may be determined by manual testing of questioned areas. Wheel records and test results shall be maintained for wheels found to be conforming under this paragraph.

18.5 Magnetic Particle Inspection

18.5.1 Purpose

To supplement visual inspection of the surface of new wheels by detecting discontinuities that may be harmful to wheel service.

18.5.2 Scope

This test method covers the wet fluorescent magnetic particle inspection of the plates of wheels ordered to this specification.

AAR Manual of Standards and Recommended Practices

Wheels and Axles

M-107/M-208

18.5.3 Equipment

18.5.3.1 Magnetizing Apparatus

The magnetizing apparatus shall be capable of inducing suitable magnetic fields within the entire plate area of the wheel to facilitate the disclosure of both circumferentially and radially oriented discontinuities. The magnetizing currents used shall be large enough to induce magnetic fields of sufficient intensity to disclose surface discontinuities 1/4 in. long. The use of prod-type contacts is prohibited.

18.5.3.2 Lighting Apparatus

The inspection shall be performed in a darkened booth with the area of the wheel to be inspected illuminated with properly filtered black light. The black light shall have a predominant wavelength of 4000 Å to 3400 Å, and the intensity of the black light, measured at the surface to be inspected, shall be a minimum of 75 footcandle at point of inspection.

18.5.3.3 Inspection Medium

18.5.3.3.1 The bath or solution should be prepared using a suitable carrier fluid and fluorescent magnetic particles and renewed monthly or more often if contamination is noted in weekly tests. Each time the bath is renewed, the bath container should be cleaned out and the agitation and circulation system should be flushed with 1 or 2 gal of clean carrier. Filtering screens should be removed and cleaned by blowing with air. In preparing the new bath, only recommended materials should be used. The amount of powder should be carefully weighed out in accordance with the material manufacturer's recommendation and be added directly to the bath containing the correct amount of carrier. It is recommended that powder be added directly over the sump so that it will be drawn quickly into the pump and circulated. The amount of carrier and powder used and the date of preparation should be recorded on a regular form set up for this purpose, as outlined in paragraph 18.5.3.3.6.

18.5.3.3.2 Concentration and contamination of the bath solution should be tested weekly as follows: pump and agitation system should be operated for 20 minutes and then the solution should be run through a hose and nozzle for 30 seconds. Using a regular 100-mL centrifuge tube, fill the centrifuge tube with 100 mL of the solution. Allow the bath solution to settle for the time recommended by the manufacturer of the type of powder used, making sure that the tube is not subjected to excessive vibration during the settling period. Each horizontal division represents 0.1 mL, and a correct reading in volume of particles must be as stipulated by the powder manufacturer. The check also should note contamination caused by dirt, chips, or other foreign matter settling with the powder. Contamination also is indicated when the carrier appears to acquire more than usual fluorescence or when the magnetic particles appear to have lost fluorescent qualities. This condition can be readily observed when the settling tube is exposed to ultraviolet light. The readings obtained are to be shown on the regular report form as outlined in paragraph 18.5.3.3.6.

18.5.3.3.3 The ultraviolet light should be tested weekly using a light meter, such as a type having 75-footcandle scale with a 10× multiplying disc or equivalent or a meter that responds specifically to the ultraviolet range of 3650 Å (365 nm). The latter type meters are calibrated in microwatts per square centimeter. The meter should be held a fixed distance of 15 in. from the light source (from the black light filter surface to the meter-sensing element) and should have a minimum meter reading of 525 μW/cm².

18.5.3.3.4 The conversion factor from footcandles (for light meters) to microwatts per square centimeter is 5.7 times the footcandle reading (at 15 in. distance).

18.5.3.3.5 The maximum allowable footcandles will be left to the discretion of the user dependent on the degree of brilliance desired to obtain satisfactory inspection conditions. Before taking readings, it should be known that the glass black light filters are clean. Reports of this test are to be shown on regular form as outlined in paragraph 18.5.3.3.6.

18.5.3.3.6 A regular form should be prepared embodying the information to be shown on monthly and weekly tests as outlined above, and this form should be on hand at the wheel shop and available to AAR inspectors.

18.5.3.3.7 Prepackaged, self-contained solutions, including aerosol sprays, may be used provided that the following conditions are met:

18.5.3.3.7.1 The solution is agitated frequently to ensure that magnetic particles remain in solution.

18.5.3.3.7.2 A detectability test is performed daily on each package in use and a record is kept per paragraph 18.5.3.3.6. The test consists of inspection of a test wheel with a known crack of at least 1/4 in. long or an equipment manufacturer's approved test piece that will indicate and verify the following:

- Proper brilliance of ultraviolet light
- Proper concentration of bath solutions
- Proper magnetic power source and operation of equipment

Note: Test wheel or test piece must be thoroughly cleaned of the last test indicators before testing. This must be verified by ultraviolet light before the test is started.

18.5.4 Preparation for Inspection

The surface shall be scale free before magnetic particle inspection.

18.5.5 Detection of Discontinuities

This inspection shall be performed to detect discontinuities whose axes may be in any direction. Continuous or residual magnetization shall be used with adequate coverage by the inspection medium.

18.5.6 Time of Inspection

The magnetic particle inspection shall be performed following final machining or grinding on wheel plate.

18.5.7 Rejection

Rejection of magnetic particle discontinuity indications must take place if any plate surface indication is 1/4 in. in length or longer in any direction. Discontinuities may be removed by machining or grinding where sufficient stock remains. Such wheels shall be retested by magnetic particle inspection.

18.6 Personnel Requirements for Ultrasonic Inspection

18.6.1 All personnel engaged in ultrasonic operations will be qualified to NDT Level I according to the qualification requirements as defined by the American Society for Nondestructive Testing, Recommended Practice SNT-TC-1A, latest edition.

18.6.2 All personnel conducting inspection setups and machinery setups will be trained and qualified to meet the criteria for NDT Level II for ultrasonic testing as defined by the American Society for Nondestructive Testing, Recommended Practice SNT-TC-1A, latest edition.

18.6.3 Each manufacturer will employ the services of an individual who will be trained and qualified to meet the criteria for NDT Level III for ultrasonic testing as defined by the American Society for Nondestructive Testing, Recommended Practice SNT-TC-1A, latest edition.

19.0 CERTIFICATION

At the purchaser's request, a certification shall be made the basis of acceptance of the material. This shall consist of a copy of the manufacturer's test report that the material has been sampled, tested, and inspected in accordance with the provisions of the specification. Each certificate so furnished shall be signed by an authorized agent of the supplier or manufacturer.

AAR Manual of Standards and Recommended Practices
Wheels and Axles

M-107/M-208

20.0 REJECTION

20.1 Wheels represented by samples that fail to conform to the requirements of these specifications will be rejected.

20.2 Wheels that show injurious defects subsequent to original inspection and acceptance at the manufacturer's works, or elsewhere, will be rejected, and the manufacturer shall be notified.

21.0 REHEARING

Samples tested in accordance with this specification that represent rejected wheels shall be held for a period of 14 days from date of the test report. In case of dissatisfaction with the results of the tests, the manufacturer may make claim for a rehearing within that time.

22.0 This specification includes Appendices A and B; and Figs. B.1 through B.14.

APPENDIX A
AUTHORIZATION FOR DELIVERY OF WHEELS FOR AAR INTERCHANGE SERVICE

1.0 Each manufacturer must obtain an authorization for delivery of wheels for AAR interchange use from the Committee prior to delivery.

2.0 The manufacturer applying for delivery authorization must provide the AAR with an electronic copy of the following documentation.

2.1 A descriptive drawing of the wheel type as it will be produced. The descriptive drawing will provide the following information:

2.1.1 A full-scale drawing showing the wheel cross-section from center of the hub to top of the flange. The drawing may show either a single profile with tolerances or, preferably, two profiles, with one depicting the minimum inner tolerances and the other the maximum outer tolerances in such a way that a wheel section laid on the drawing would fall between the two profiles. This would allow analysis of wheels produced to this drawing.

2.1.2 A notation of the wheel type and heat-treatment classes of the wheels to be produced.

2.2 A brief description of the design analysis method and the results of the analysis. The preferred analytic procedure is that covered in S-660. If there is no design analysis, a statement should be made to this effect along with a summarization of the design considerations. If the applicant would like the AAR to perform the S-660 design analysis on a contract basis, the applicant should request details from the AAR.

2.3 A statement advising the specific areas in which the wheel design may not be compatible with normal shop machinery and handling equipment, standard storage facilities, and wheel transport cars in general use.

3.0 Authorization for the delivery of a wheel type will be approved by the Committee if deemed suitable for interchange service based on a review of wheel data submitted by the manufacturer. The initial authorization will be for the delivery of 32,000 wheels. If the manufacturer requests additional delivery authorizations, the second will be for 20,000 wheels (52,000 total) and the third will be for 20,000 wheels (72,000 total). Additional allotments or unconditional approval for unlimited quantities will be given after that, provided all required conditions are met.

3.1 A new wheel type (such as CH-36, CJ-36, or J-33) that is made for the first time by the requesting manufacturer will require the following prior to being granted unconditional approval. If necessary, WABL will designate a sponsor railroad to assist the manufacturer in meeting these requirements.

3.1.1 A minimum of 5,000 wheels installed from the first allotment will have been tracked to provide mileage and will have achieved 200,000 miles in service.

3.1.2 Ultrasonic testing to wheelshop requirements for turned wheels will be performed for 30 or more wheels with at least 200,000 miles of service and with sufficient rim metal to be reapplied. Provided all other criteria are met, upon successful completion of ultrasonic testing, conditional approval, unlimited quantity will be granted. The 30 wheels will then be placed in service and tracked. Ultrasonic testing to wheelshop requirements of turned wheels will be performed for 10 of the 30 wheels reapplied after 100,000 miles additional service. Provided all other criteria are met, upon successful completion of the ultrasonic testing, unconditional approval will be granted. Test costs will be paid by the proponent, and data provided in the form of C-scans will be captured with an AAR observer present and provided to WABL.

AAR Manual of Standards and Recommended Practices
Wheels and Axles

M-107/M-208

APPENDIX A

3.1.3 At least one out of every 1,000 wheels produced in the initial allotment will be tested for microcleanliness according to paragraph 9.0 of this specification. Results will be reported to the Wheels, Axles, Bearings, and Lubrication Committee Manager within 90 calendar days. Electronic reporting is preferred. Send results to

Email: wabl@aar.com Facsimile: 719-585-1895 Mail: AAR WABL Committee Manager Transportation Technology Center Inc. P.O. Box 11130 Pueblo, Colorado 81001

3.2 Each authorization after the initial authorization will be granted only after satisfactory performance is indicated by a review of service data submitted on the wheel by the manufacturer as well as service data from AAR records. Authorization may be withdrawn if service performance so dictates.

4.0 Changes to any wheel design by the producer must be reviewed by the Committee before delivery authorization may be granted.

APPENDIX B
QUALIFICATION OF MANUFACTURER'S PLANT AS A PRODUCER OF
WHEELS FOR AAR INTERCHANGE SERVICE

1.0 Applications for approval are to be submitted to the AAR. Applications shall be provided in electronic file format and must provide a general description of the facility and the equipment to be used in the production of wheels. In the event it is desired to deliver mounted wheel sets, information indicating that equipment is available to comply with the wheel mounting requirements of the *AAR Manual of Standards and Recommended Practices*, Section G, Part II, "Wheel and Axle Manual" should be included.

2.0 After review of the data submitted with the application, the Committee will authorize the applicant to contact the AAR for information concerning product testing. Normally this will consist of the applicant furnishing three wheels, at applicant's expense, for testing by the AAR. All costs are to be paid by the applicant upon notification of the testing charges.

3.0 Subsequent to the satisfactory completion of the tests and approval by the Committee of test results, the AAR will inspect the plant where the wheels are to be produced for proper equipment and, if mounted wheels are to be provided, an AAR inspection will be arranged for the wheel shop. These inspections will require that all out-of-pocket expenses be borne by the applicant. These inspections can be arranged concurrently with the test program if the applicant so requests.

4.0 All plants desiring to maintain their status as an AAR-approved manufacturer of wheels for use in AAR interchange service must be inspected yearly with costs of inspection to be borne by the wheel producer. Every effort will be made to inspect all plants in a given area at one time to minimize costs, which will be prorated among the companies inspected.

5.0 In the event that a facility ceases production for less than 1 year and has not received its scheduled annual inspection, an inspection of the facility is required prior to the delivery of any items for use in interchange service. In the event a plant ceases production of wheels for AAR interchange service for more than 60 days and less than 1 year, the AAR must be notified no later than 2 weeks prior to reopening. In the event a plant ceases production of wheels for AAR interchange service for more than 1 year, requalification will be required prior to delivery of any items for use in AAR interchange service. An AAR inspection of the plant will be required, and normally, the provisions of Appendix A will apply for all wheel designs that have been given an authorization in accordance with the procedure outlined in paragraph 2.0 and subparagraphs. The Committee may elect to require testing of wheels in accordance with Appendix B, paragraph 2.0.

6.0 In addition to the foregoing, wheel manufacturers must meet the requirements of the *AAR Manual of Standards and Recommended Practices*, Section J, Specification M-1003, "Specification for Quality Assurance."

7.0 All plants desiring to maintain their status as an AAR-approved manufacturer of wheels for use in AAR interchange service must also have their steel suppliers, shot peening, and heat-treating subcontractors inspected if they do not use their own facility. These inspections will be made in conjunction with the facility inspection, and the cost will be borne by the applicant.

8.0 Wheel manufacturers using a native language other than English are responsible for the accurate communication of all applicable AAR and customer requirements within the plant.

8.1 Plant practices and the final product must conform to the English language versions of any applicable standards or specifications.

8.2 Critical records are defined as the standards, internal procedures, and forms necessary to demonstrate compliance with this Specification M-107/M-208 and with *MSRP* Section J, Specification M-1003. Critical records must be kept up to date with production and be maintained in English.

**AAR Manual of Standards and Recommended Practices
Wheels and Axles**

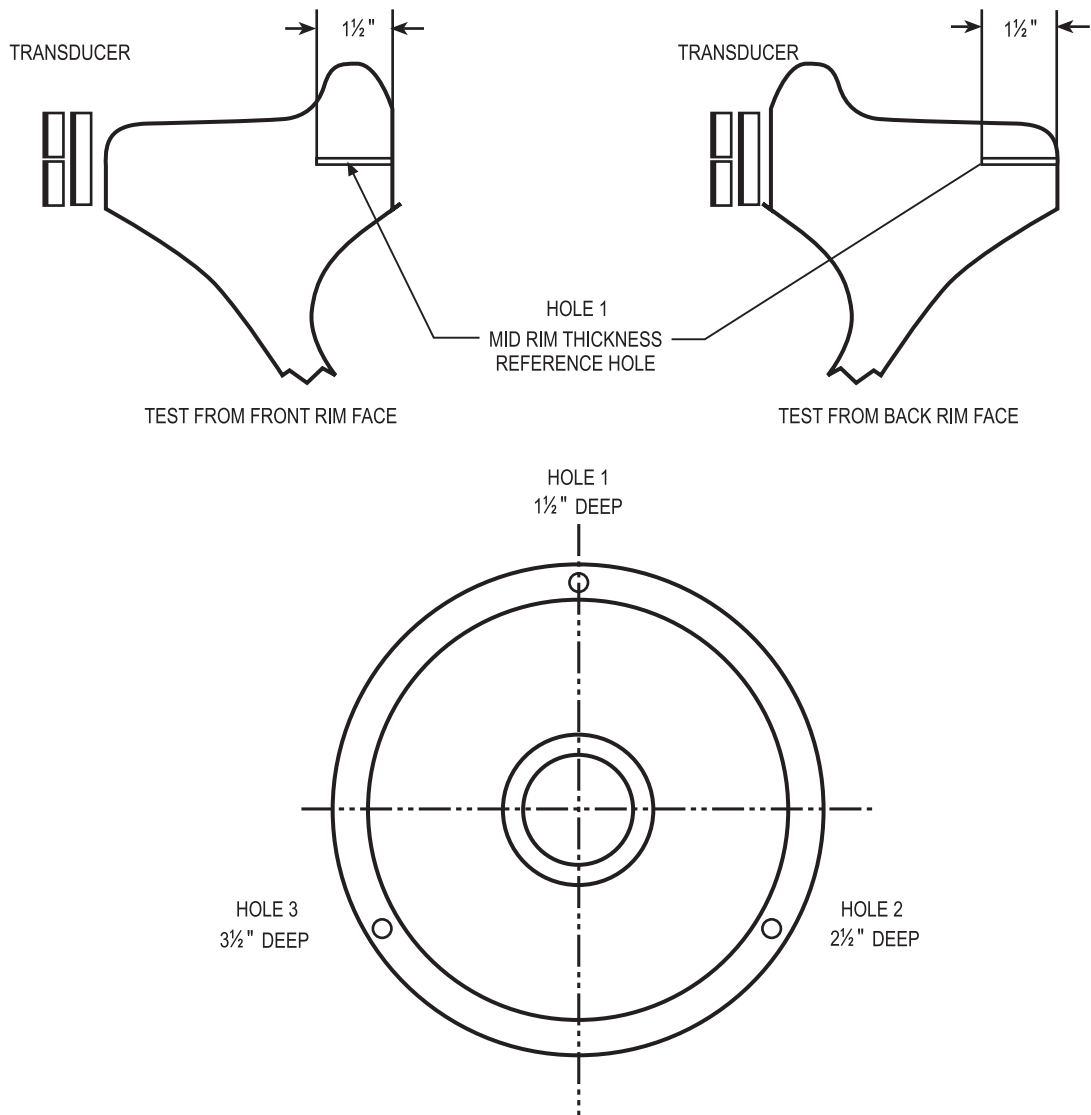

**Fig. B.1 Typical reference standard for rim face ultrasonic test
Paragraphs 18.4.3.2 and 18.4.3.4
Hole #1 reference hole
Holes #2 and #3 used for distance amplitude correction (DAC)**

AAR Manual of Standards and Recommended Practices
Wheels and Axles

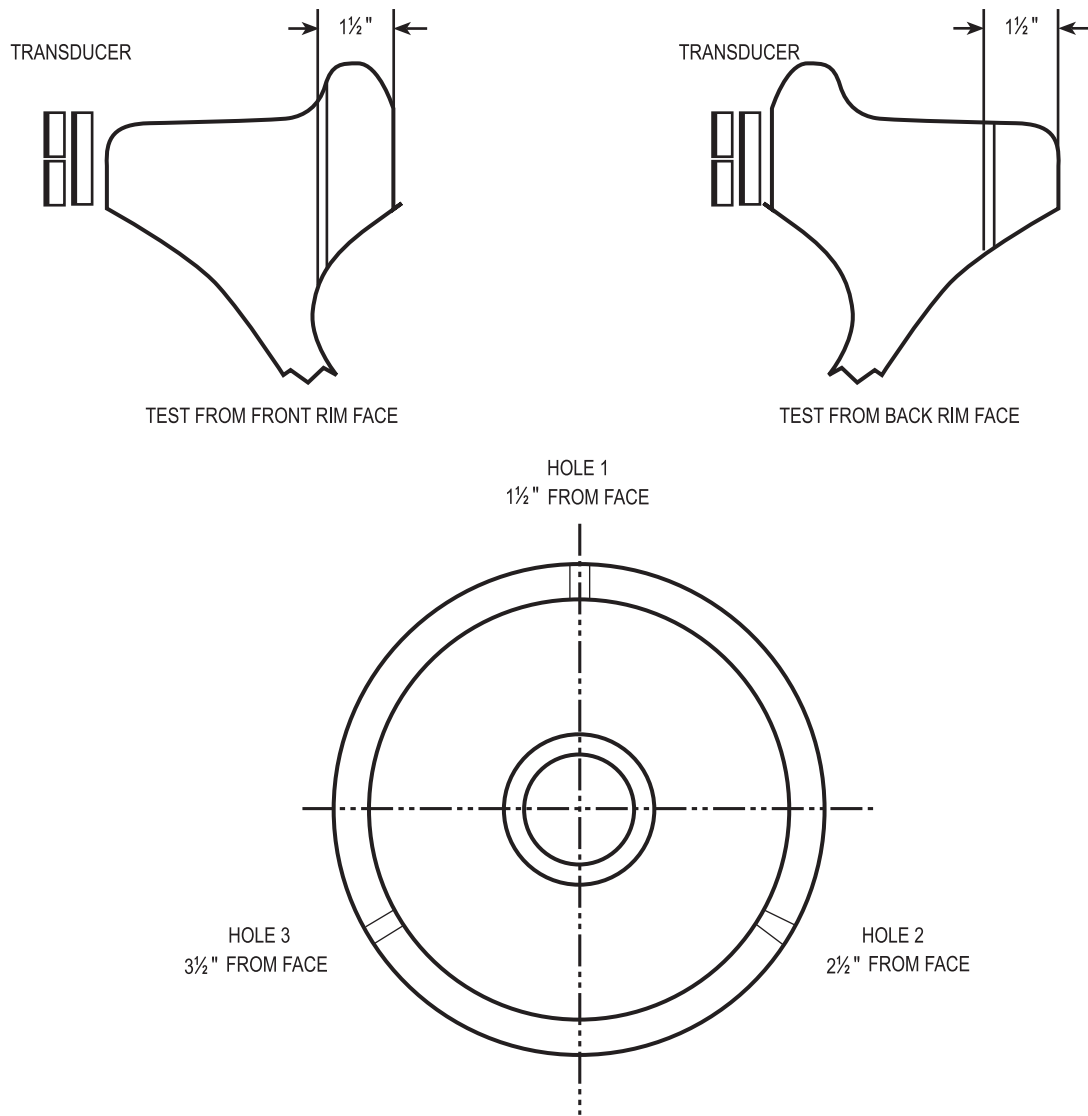

Fig. B.1.1 Axial rim test
Paragraphs 18.4.3.2 and 18.4.3.4.1
Alternate configuration for distance amplitude correction

**AAR Manual of Standards and Recommended Practices
Wheels and Axles**

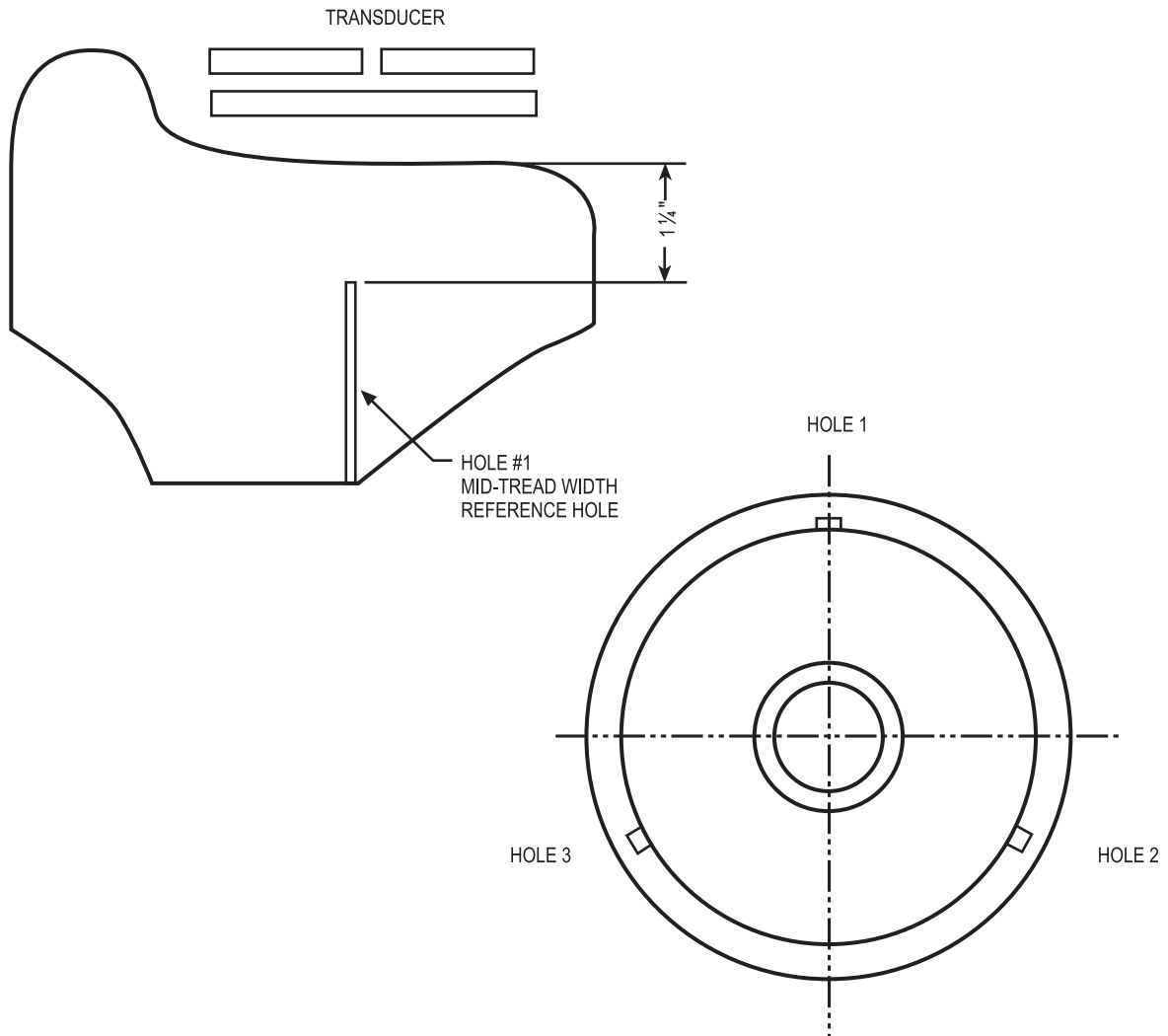

Table B.1

Wheel Design	Distance below Tread Surface		
	Reference Hole #1	Hole #2	Hole #3
One-wear two holes	1 1/4 in.	3/4 in.	
Two-wear two holes	1 1/4 in.	3/4 in.	
Multi-wear three holes	1 1/4 in.	3/4 in.	2 1/4 in.

Fig. B.2 Typical reference standard for rim tread ultrasonic test
 Paragraphs 18.4.3.3 and 18.4.3.4.2
 Hole #1 reference hole
 Hole #2 and #3 used for distance amplitude correction (see Table B.1)

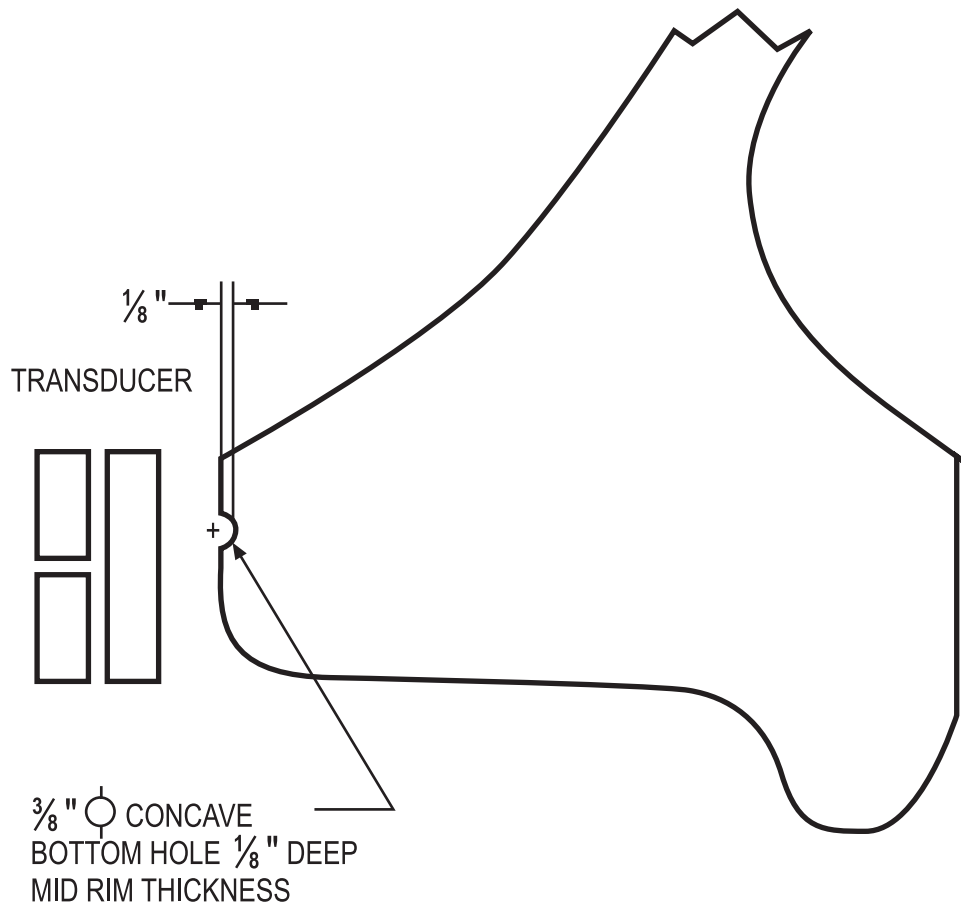

Fig. B.3 Axial rim test
Paragraph 18.4.3.6

AAR Manual of Standards and Recommended Practices
Wheels and Axles

M-107/M-208

APPENDIX B

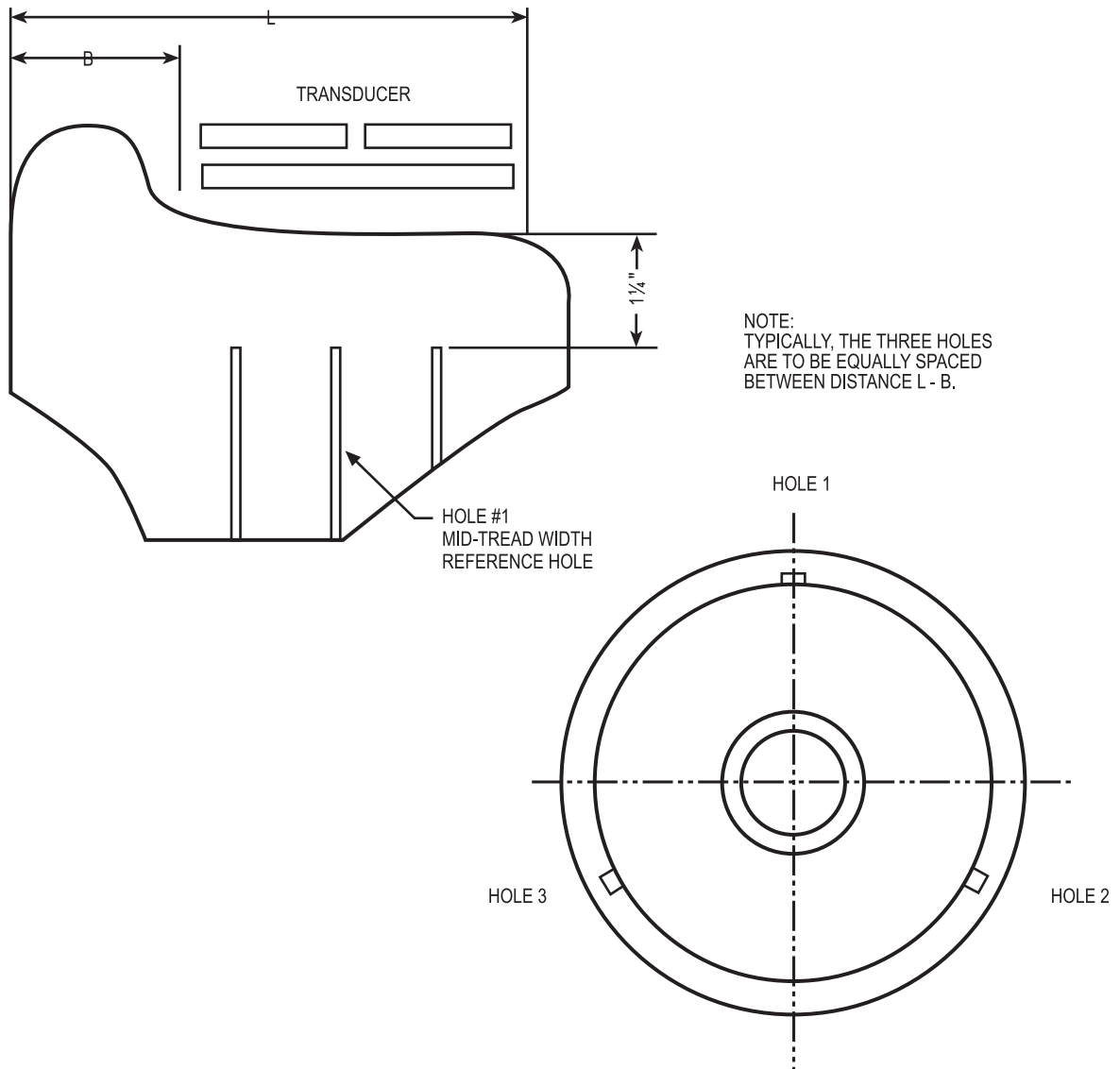
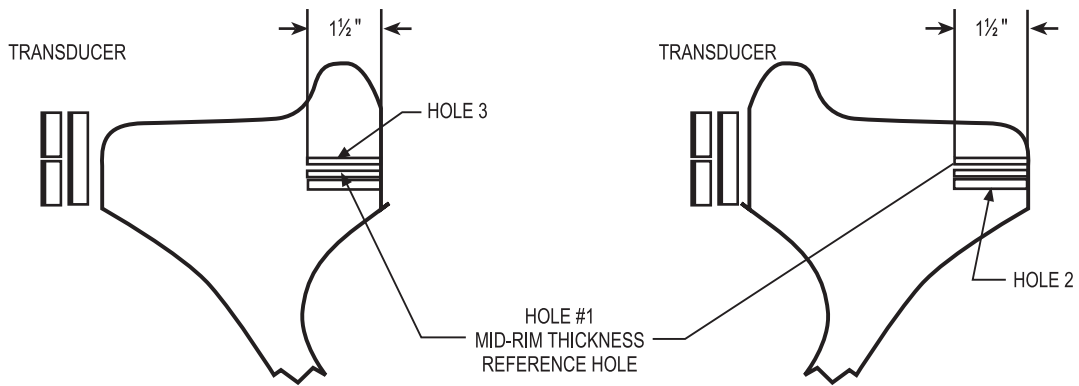

Fig. B.3.1 Tread rim test
Paragraph 18.4.4.2

AAR Manual of Standards and Recommended Practices
Wheels and Axles



NOTE:
TYPICALLY, THE THREE HOLES
ARE TO BE SPACED WITHIN THE
FLAT PORTION OF THE RIM FACE.

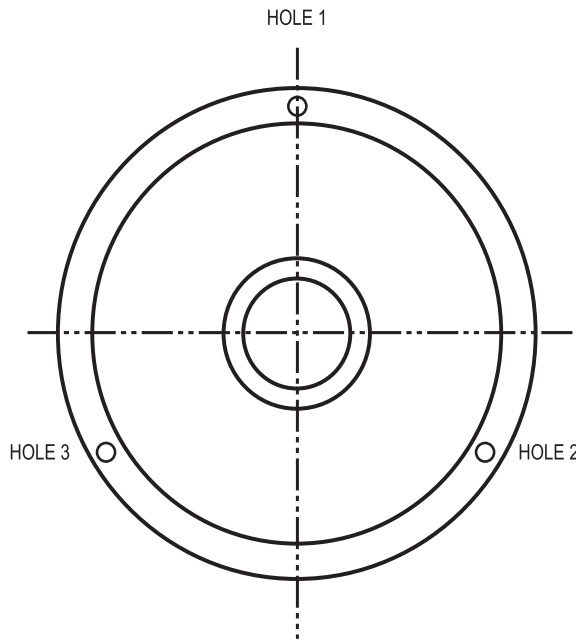
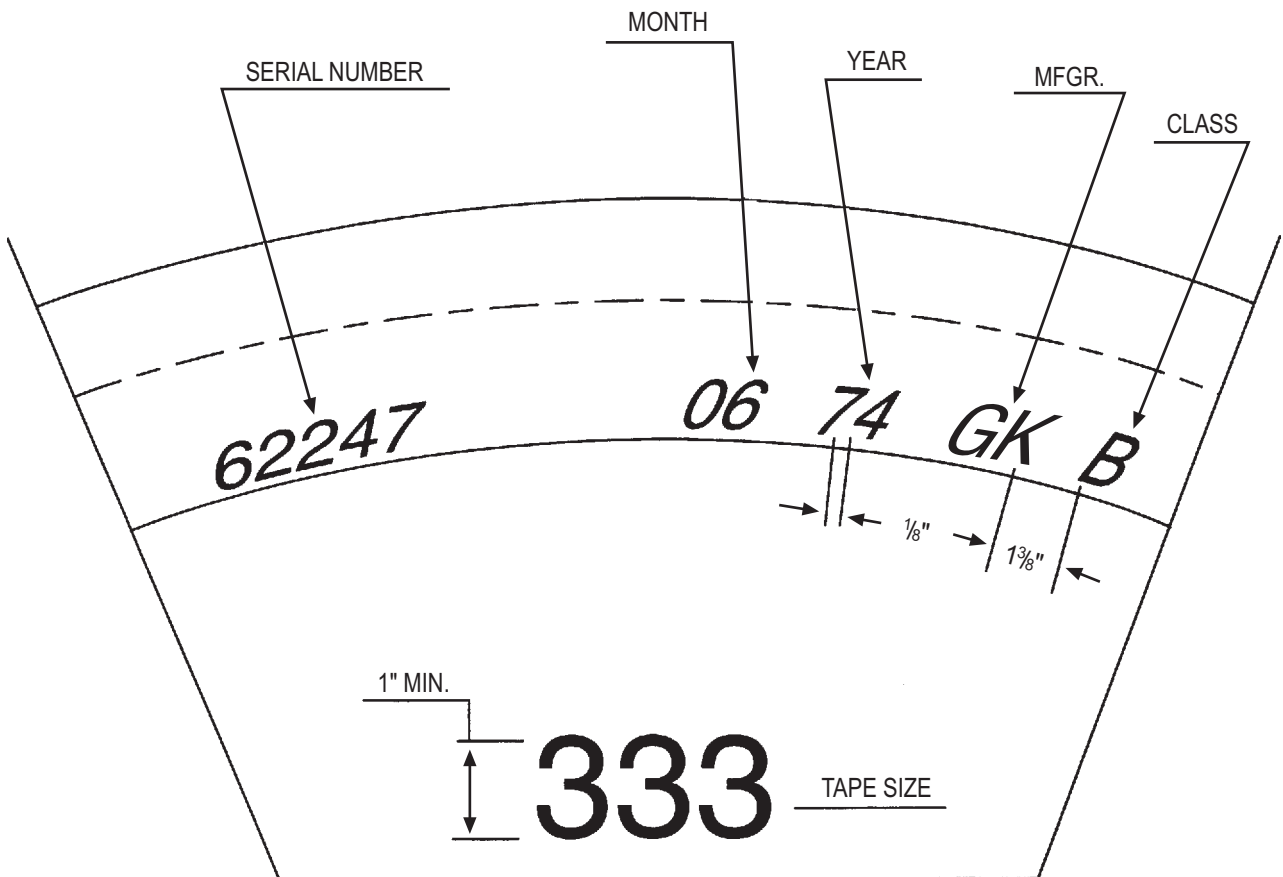

Fig. B.3.2 Axial rim test
Paragraph 18.4.4.2

AAR Manual of Standards and Recommended Practices
Wheels and Axles

M-107/M-208

APPENDIX B



- Note 1** Stamping is to consist of manufacturer's serial number, date of manufacture, manufacturer's identification, and class of heat treatment. Stamping is limited to 14 characters, and the design designation shall be stencilled on the back plate with paint using characters at least 1 in. in height.
- Note 2** Stamping is to be spaced a minimum of 1/8 in. between characters and 1 3/8 in. between groups. The stamping shall be located not less than 1/4 in. from the inner edge of the rim.
- Note 3** Dies used to produce characters shall be not less than 3/8 in. in nominal height at crest, and hot stamping shall be nominally 3/32 in. in depth. Italicized characters (sloping upward to right) shall be used.
- Note 4** All wheels will be marked for class using letters L, A, B, C, or D, as appropriate.
- Note 5** All stamped characters must be stamped with a low-stress die design to a minimum depth of 0.015 in. or an AAR-approved alternative.

Fig. B.4 Marking of locomotive wheels rim stamping
Paragraph 17.1

AAR Manual of Standards and Recommended Practices
Wheels and Axles

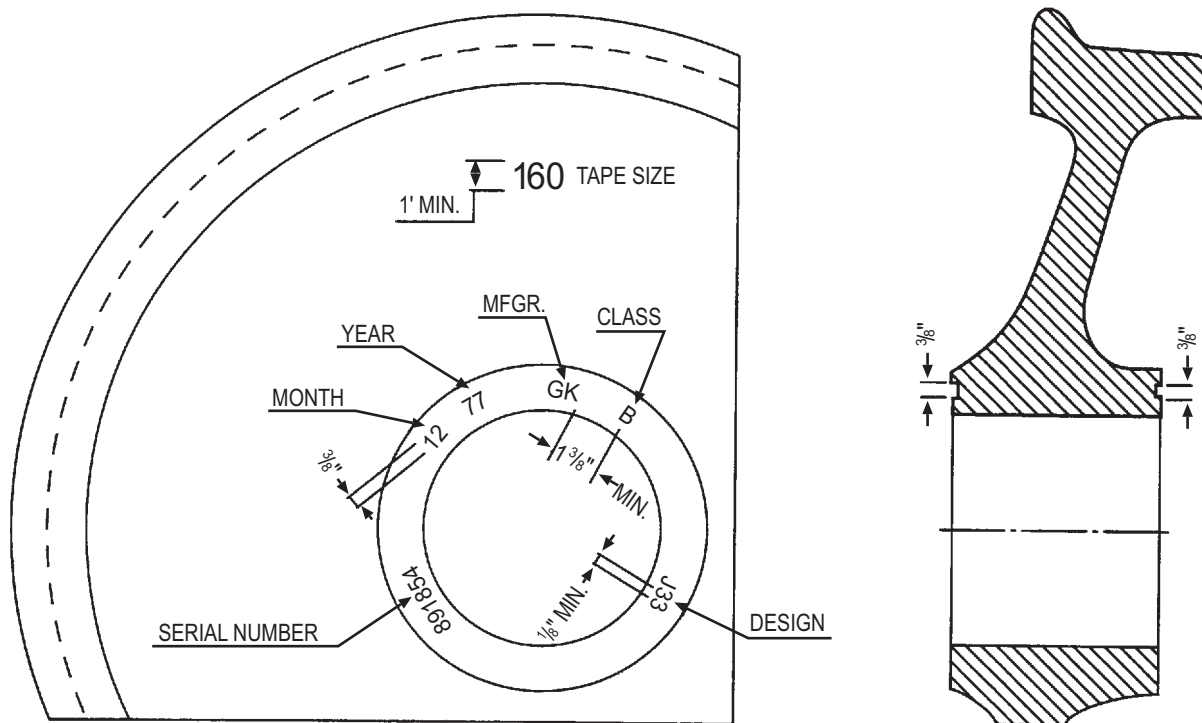

- Note 1** When ordered, locomotive wheels and wheels for passenger service may be ordered stamped on the front or back hub face. Wheels for freight service are stamped on the back hub face.
- Note 2** Stamping is to consist of manufacturer's serial number, date of manufacture, manufacturer's identification, class of heat treatment, and design designation in the order shown above. The hub stamping of locomotive wheels may be applied by the purchaser after final machining of the hub. Wheels that are to be marked by the purchaser should be furnished with all marking stencilled on the front plate with paint using characters at least 1 in. in height.
- Note 3** Stamping is to be spaced a minimum of 1/8 in. between characters and a minimum of 1 3/8 in. between groups and located approximately central of the hub face. No wheel manufactured after May 1, 2009, may be bored and applied with any portion of the wheel manufacturer's hub stamp closer than 1/8 in. from the inner hub diameter and no closer than 1/8 in. from the outer hub diameter. No wheel manufactured before May 1, 2009, may be bored and applied with any portion of the wheel manufacturer's hub stamp breaking over the edge of the inner or outer hub diameter.
- Note 4** Stamps used to produce characters shall be not less than 3/8 in. in height and shall not have sharp edges.
- Note 5** All wheels will be marked for class using letters L, A, B, C, or D, as appropriate.
- Note 6** The three groups (1) design; (2) serial number; and (3) date of manufacture, manufacturer, and class will be spaced approximately equidistantly around the hub face.
- Note 7** All stamped characters must be stamped with a low-stress die design to a minimum depth of 0.015 in. or an AAR-approved alternative.

Fig. B.5 Marking of carbon steel wheels hub stamping
Paragraph 17.1

AAR Manual of Standards and Recommended Practices
Wheels and Axles

M-107/M-208

APPENDIX B

Manufacturer's Identification	Manufacturer	Location	Cast or Wrought	No Longer in Production
AW	Scaw Metals	Germiston, South Africa	C	
C	Abex Rail **	Calera, Alabama	C	X
CO	Datong ABC Castings Company LTD	Datong, Shanxi Province, China	C	
CZ	Amsted Maxion (Formerly lochpe-maxion S.A.)	Cruzeiro, Brazil	C	
FM	FM Fundiciones de Hierro y Acero	Mexico	C	X
GB	Griffin Wheel Company	Bensenville, Illinois	C	X
GC	Griffin Wheel Company	Columbus, Ohio	C	
GI	Griffin Wheel Company	Kansas City, Kansas	C	
GK	Griffin Wheel Company	Keokuk, Iowa	C	
GL	Griffin Wheel Company	Colton, CA	C	X
GS	Griffin Wheel Company	Bessimer, Alabama	C	
GT	Griffin Wheel Company	Winnipeg, Canada	C	
GY	Griffin Wheel Company	St. Hyacinthe, Canada	C	X
RZ	Tianrui Group Foundry Co. Ltd	Ruzhou, Henan Province, PRC	C	
S	Abex **	St. Louis, Missouri	C	X
SJ	Abex	Johnstown, Pennsylvania	C	X
SO	ABC Rail (formerly Abex)	Calera, Alabama	C	X
T	Abex **	Toledo, Ohio	C	X
TA	Tonghe Wheel Company	Xinyang City, Henan Province, PRC	C	
WI	Rail Wheel Factory (Formerly Wheel and Axle Plant)	Yelahanka, Bagalore, India	C	
A	Armco		W	X
BV	B.V.V. (Formerly VSG)	Bochum, Germany	W	
BW	Bethlehem		W	X
CS	Comsteel	Waratah NSW, Australia	W	
CW	U.S. Steel	Pittsburg, Pennsylvania	W	X
DW	Bonatrans a.s. (Formerly ZDB)	Bohumin, Czech Republic	W	
EV	Evrax Group	Nizhni Tagil, Russia	W	
EW	Edgewater Steel LTD	Oakmont, Pennsylvania	W	X
FW	Creusot-Loire	France	W	X
G	U.S. Steel	Gary, Indiana	W	X
HW	Maanshan Iron and Steel Co. LTD	Anhui, Province, P.R.C.	W	
JW	Sumitomo Metal Industries LTD	Osaka, Japan	W	
KW	Klockner	Germany	W	X
LW	Lucchini Sidermeccanica SpA (Formerly Gruppo Lucchini)	Loveve, Italy	W	
MW	MWL (Formerly Mafersa)	Cacapavz, Sao Paulo, Brazil	W	
NW	Niznedneprovssky Tube Rolling Plant (NTRP)	Dnepropetrovsk, Ukraine	W	
P	British Steel	UK	W	X
QW	Construcciones y Auxiliar de Ferrocarriles (CAF)	Beasain, Spain	W	
RW	S. C. SMR S.A (Formerly SMR/MECANO)	Bals, Romania	W	
SW	Standard Steel LLC	Burnham, Pennsylvania	W	
TW	Adtranz	UK	W	X
TY or TZ (TY not used after 10/ 06)	Taiyuan Heavy Industry CO., LTD	Taiyuan, Shanxi Province, PRC	W	
VK	Vyksa Steel Works	Nizhegorodsky Region, Russia	W	
VW	Valdunes	Dunkerque & Valenciennes, France	W	
ZW	Canadian Steel Wheel	Canada	W	X

** The letters C, S, or T directly precede the wheel serial number for wheels manufactured prior to about April 1978

Fig. B.6 AAR-approved manufacturers

IMPLEMENTED 08/2012

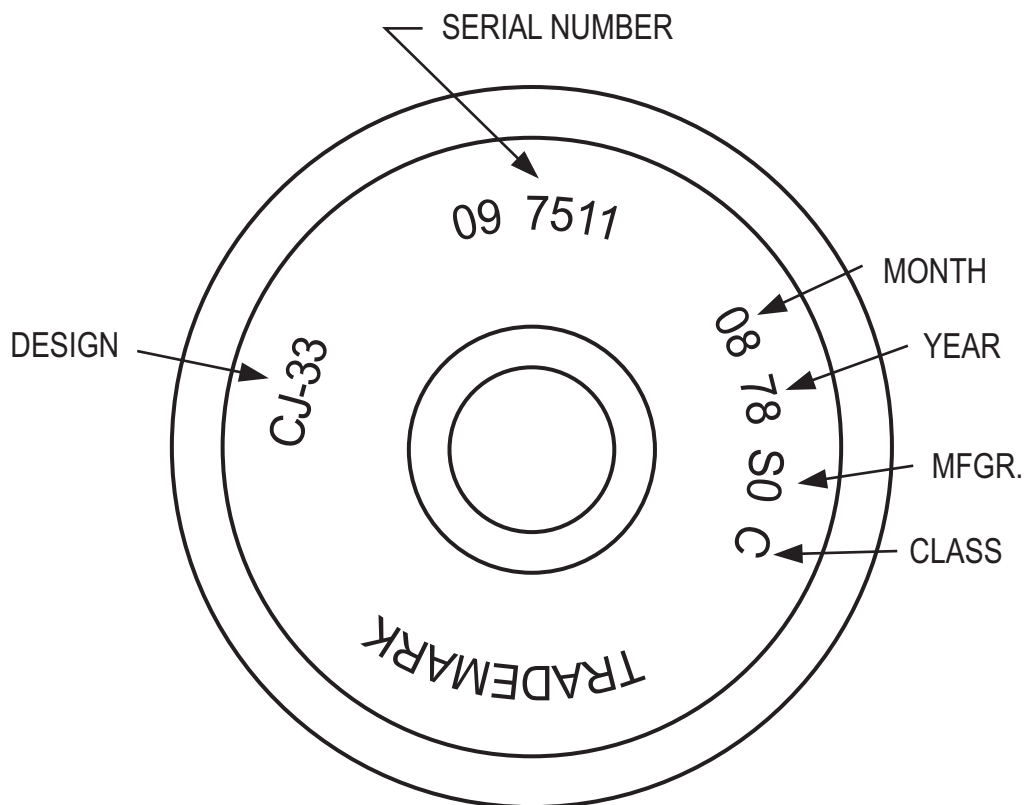

- Note 1.** Characters to be cast on the back plate of wheels shall, at least, show the manufacturer's serial number, date of manufacture, manufacturer's identification, class, and design designation.
- Note 2.** Cast markings shall be legible characters, at least 1 in. high and so spaced to allow related characters to be readily distinguished as a group.
- Note 3.** All wheels shall be marked for class using letters L, A, B, C, or D, as appropriate.
- Note 4.** The three groups (1) design; (2) serial number; and (3) date of manufacture, manufacturer, and class must be clearly separate.

Fig. B.7 Raised markings on cast carbon steel wheels
Paragraph 17.1

**AAR Manual of Standards and Recommended Practices
Wheels and Axles**

M-107/M-208

APPENDIX B

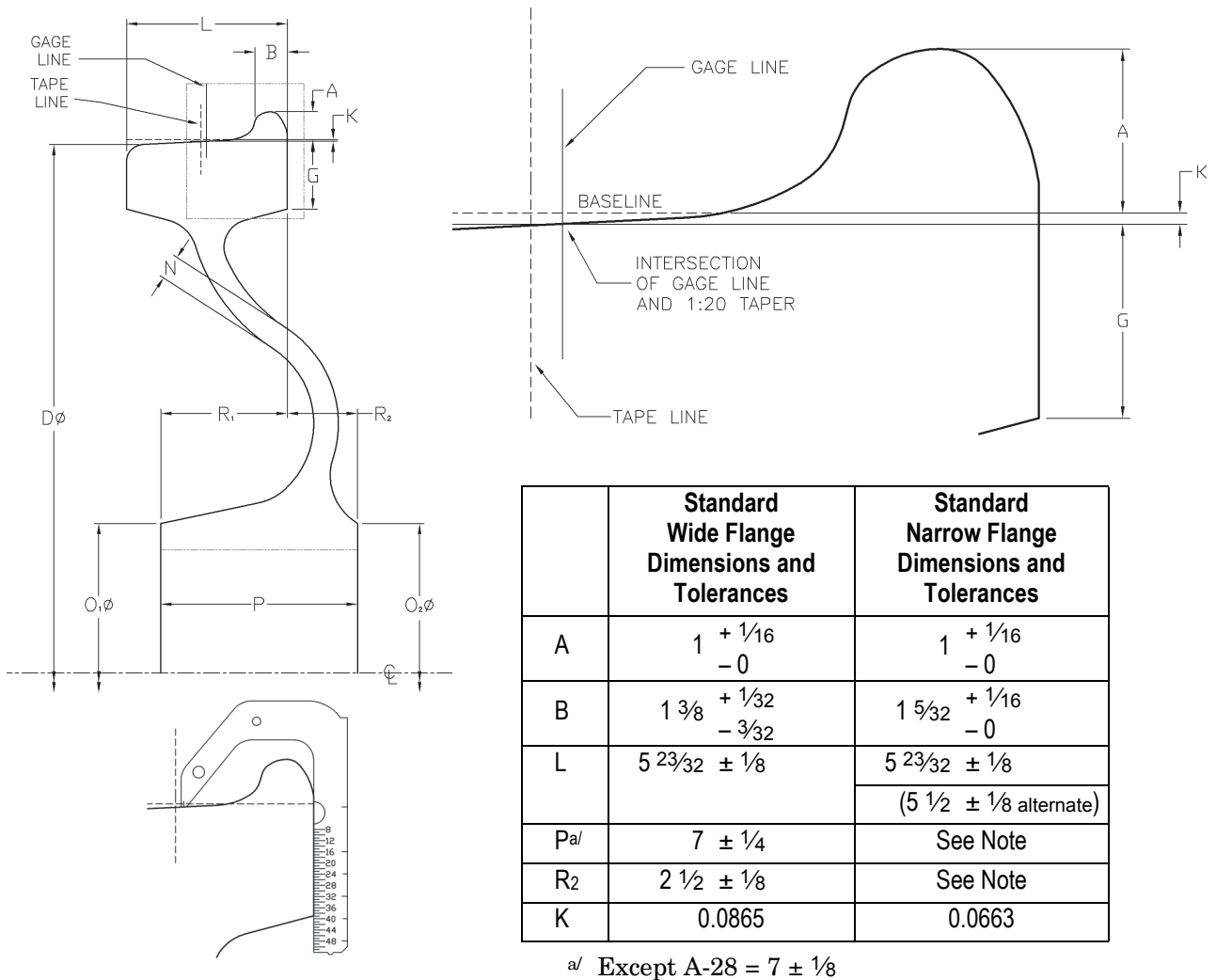

**Fig. B.8 Standard dimensions and tolerances and permissible variations
Paragraphs 2.1 and 15.1**

Note: For standard wheel types and for dimensions and other data not shown above, see Figs. B.9 through B.14.

AAR Manual of Standards and Recommended Practices
Wheels and Axles

APPENDIX B

M-107/M-208

9.0 PERMISSIBLE VARIATIONS IN DIMENSIONS NOT SHOWN BY TOLERANCES ON FIGS. B.9 THROUGH B.14

9.1 Inside Diameter—Front Face of Rim

The inside diameter of the rim at the front face of the wheel shall not differ from that at the back face of the wheel by more than 1/4 in.

9.2 Thickness of Rim

In any wheel, the radial thickness of the rim shall not vary more than 1/8 in. around the wheel.

9.3 Corner at Inside Diameter of Back Face

A sharp corner is preferable to facilitate measurement. In any case, the radius of the corner shall not exceed 1/8 in.

9.4 Plane of Back Face

When wheels are gauged with a straight edge applied to the back face of the rim, no point on the back face of narrow-flange wheels more than 1 1/4 in. from the inside edge of the rim shall be more than 1/32 in. from the straight edge. For wide-flange wheels, no point on the back face of the rim shall be more than 1/32 in. from the straight edge. For narrow- and wide-flange wheels, the back face of the rim measured on the circumference at a distance 1 1/4 in. inward from the apex of the flange must be in plane within 0.040 in. Total Indicator Reading (TIR) with respect to the plane of the front face of the rim.

9.5 Hub Wall Thickness

The thickness of the hub wall in any one wheel measured at any two points equidistant from the face of the hub shall not vary by more than 3/8 in. if the hub is not machined, nor by more than 1/8 in. if the hub is machined.

9.6 Rotundity

Tread when gauged with a ring gauge must not have an opening between tread and gauge at any point over .022 in.

9.7 Diameter of Bore

The diameter of rough bore shall not vary more than 1/16 in. over nor more than 1/16 in. under the dimensions specified by the purchaser.

9.8 Eccentricity of Bore

Eccentricity between the rough bore and tread, measured in the plane of the taping line, shall not exceed .0625 in. TIR, except that no more than 5% of wheels delivered may be over .0625 in. TIR and these must not exceed .09375 in. TIR.

**AAR Manual of Standards and Recommended Practices
Wheels and Axles**

M-107/M-208

APPENDIX B

IMPLEMENTED 05/2012

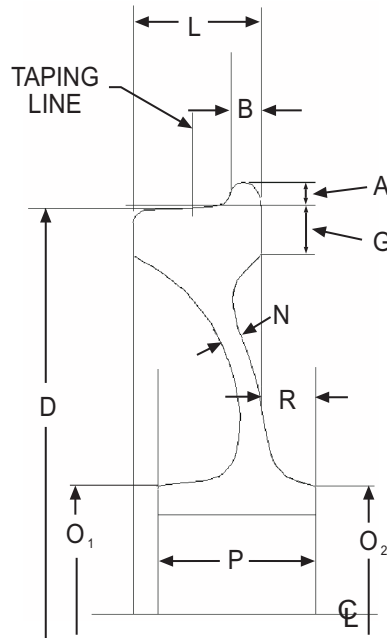

STANDARD AAR WHEEL TYPES—WIDE-FLANGE CONTOUR—FOR FREIGHT CAR SERVICE—CARBON STEEL												
AAR TYPE	A-28 CA-28	E-28 CE-28	A-30 CA-30	J-33 CJ-33	M-33 CM-33	P-33 CP-33	H-36 CH-36	J-36 CJ-36	K-36 CK-36	B-38 CB-38	C-38 CC-38	D-38 CD-38
STATUS DATE	STND 1952	STND 1985	STND 1946	STND 1956	STND 1961	STND 1984	STND 1962	STND 1962	STND 1962	STND 1964	STND 1964	
EFFECTIVE DATE	1971	7/1/85	1971	1968	1968	3/1/85	10/1/72	1968	1968	9/1/73	1968	
TREAD TYPE	M-W	1-W	M-W	1-W	2-W	M-W	1-W	2-W	M-W	1-W	2-W	M-W
INTENDED AXLE CLASS	F, K	E	F, K	D, E	D, E	D, E, F, G	F, K	F, K	F, K	G	G	G
MAX. CAP. PER WHEEL (LB)	32,875	24,375	32,875	27,500	27,500	32,875	35,750	35,750	35,750	39,375	39,375	39,375

DIMENSION AND TOLERANCES—ALL ENTRIES IN INCHES, EXCEPT TAPES												
D	28 + 14 TAPES (5%–5)	28 + 14 TAPES (5%–5)	30 + 14 TAPES (5%–5)	33 + 14 TAPES (5%–5)	33 + 14 TAPES (5%–5)	33 + 14 TAPES (5%–5)	36 + 14 TAPES (5%–5)	36 + 14 TAPES (5%–5)	36 + 14 TAPES (5%–5)	38 + 14 TAPES (5%–5)	38 + 14 TAPES (5%–5)	38 + 14 TAPES (5%–5)
G (MIN)	2 1/2	1 1/2	2 1/2	1 1/4	2	2 1/2	1 1/2	2	2 1/2	1 1/2	2	2 1/2
N (MIN)	3/4	5/8	3/4	5/8	5/8	3/4	3/4	3/4	3/4	7/8	7/8	7/8
O ₁	+1 11 1/8–0	+1 10 5/8–0	+1 11 1/8–0	+1 10 5/8–0	+1 10 5/8–0	+1 11 7/8–0	+1 11 1/8–0	+1 11 1/8–0	+1 11 1/8–0	+1 12 1/8–0	+1 12 1/8–0	+1 12 1/8–0
O ₂	+1 11 1/8–0	+1 10 5/8–0	+1 11 1/8–0	+1 10 5/8–0	+1 10 5/8–0	+1 11 7/8–0	+1 11 1/8–0	+1 11 1/8–0	+1 11 1/8–0	+1 12 1/8–0	+1 12 1/8–0	+1 12 1/8–0
MAX FINISH BORE	8 7/8	8 3/8	8 7/8	8 3/8	8 3/8	9 5/8	8 7/8	8 7/8	8 7/8	9 5/8	9 5/8	9 5/8
MIN HUB WALL	1 1/8	1 1/8	1 1/8	1 1/8	1 1/8	1 1/8	1 1/8	1 1/8	1 1/8	1 1/4	1 1/4	1 1/4
P ₁	7 ± 1/8	7 ± 1/4	7 ± 1/4	7 ± 1/4	7 ± 1/4	7 ± 1/4	7 ± 1/4	7 ± 1/4	7 ± 1/4	7 ± 1/4	7 ± 1/4	7 ± 1/4
R	2 1/2 ± 1/8	2 1/2 ± 1/8	2 1/2 ± 1/8	2 1/2 ± 1/8	2 1/2 ± 1/8	2 1/2 ± 1/8	2 1/2 ± 1/8	2 1/2 ± 1/8	2 1/2 ± 1/8	2 1/2 ± 1/8	2 1/2 ± 1/8	2 1/2 ± 1/8

NOTES:

- HUB LENGTH TOLERANCE IS BASED ON FINISHED DIMENSION.
- 5 1/2 × 10 AXLE ALSO STANDARD FOR J-33 AND M-33; 5 1/2 × 10, 6 × 11, AND 6 1/2 × 12 AXLES ALSO STANDARD FOR P-33

**Fig. B.9 Standard AAR wheel types—wide-flange contour—for freight car service
Paragraphs 2.1, 15.1, and 15.2**

AAR Manual of Standards and Recommended Practices

Wheels and Axles

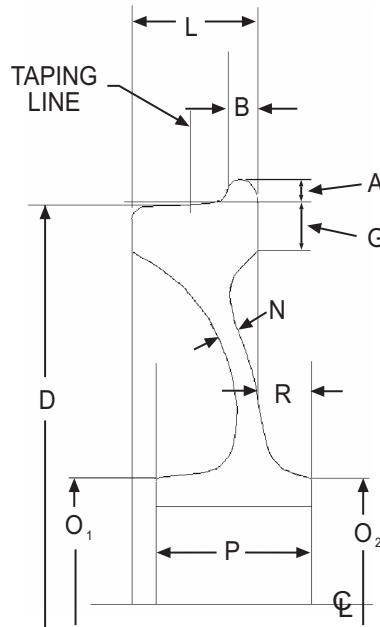

STANDARD AAR WHEEL TYPES—NARROW-FLANGE CONTOUR—FOR DIESEL LOCOMOTIVE									
AAR TYPE	F-36 CF-36	A-38 CA-38	E-40 CE-40	A-41 CA-41	A-42 CA-42	A-43 CA-43	C-42 CC-42	D-42 CD-42	E-42 CE-42
STATUS DATE	STND 1946	STND 1947	STND 1982	STND 1997	STND 1946	STND 1997	STND 1946	STND 1997	STND 1997
EFFECTIVE DATE	8/1/46	1947	3/1/83	1997	8/1/46	1997	1947	1997	1997
TREAD TYPE	M-W	M-W	M-W*	M-W*	M-W*	M-W*	M-W*	M-W	M-W

DIMENSION AND TOLERANCES—ALL ENTRIES IN INCHES, EXCEPT TAPES, SEE Fig. B.8 FOR DIMENSIONS A, B, C, and L FOR ALL NARROW-FLANGE WHEEL TYPES									
D	36" TAPES + 14 0	38" TAPES + 14 0	40" TAPES + 14 0	41" TAPES + 14 0	42" TAPES + 14 0	43" TAPES + 14 0	42" TAPES + 14 0	42" TAPES + 14 -0	42" TAPES + 14 -0
G (MIN)	2½	2½	2½	3	3	3	2½	2½	3½
N (MIN)	¾	7/8	1	1	1	1	1	1	1
O ₁	+1 13-0	+1 10¾-0	12½±1/8	12½±1/8	+1 11½-0	12½±1/8	+1 13½-0	12½±1/8	12½±1/8
O ₂	+1 13-0	+1 10¾-0	13¼±1/8	13¼±1/8	+1 11½-0	13¼±1/8	+1 13½-0	13¼±1/8	13¼±1/8
P	6½±1/8	7±1/8	6½±1/8	6½±1/8	7±1/8	6½±1/8	6½±1/8	6½±1/8	6½±1/8
R ₁	4 ¹³ / ₁₆ ±1/8	5 ⁵ / ₁₆ ±1/8	4 ¹³ / ₁₆ ±1/8	4 ¹³ / ₁₆ ±1/8	4 ⁵ / ₁₆ ±1/8	4 ¹³ / ₁₆ ±1/8	4 ¹³ / ₁₆ +1/8	4 ¹³ / ₁₆ ±1/8	4 ¹³ / ₁₆ ±1/8
R ₂	1 ¹¹ / ₁₆ f	1 ¹¹ / ₁₆ f	1 ¹¹ / ₁₆ f	1 ¹¹ / ₁₆ f	2 ¹¹ / ₁₆ ±1/8	1 ¹¹ / ₁₆ f	1 ¹¹ / ₁₆ f	1 ¹¹ / ₁₆ f	1 ¹¹ / ₁₆ f
MAX FINISH BORE	10¼	8½	9 ¹⁵ / ₁₆	9 ¹⁵ / ₁₆	9¼	9 ¹⁵ / ₁₆	10¾	9 ¹⁵ / ₁₆	9 ¹⁵ / ₁₆
MIN HUB WALL	1¾	1½	** 1½	1½	1½	1½	1¾	1½	1½

NOTES:

1. WHERE DIMENSION R₂ IS MARKED F, EXTRA STOCK OF 1/16 IN. TO 3/16 IN. OVER SPECIFIED DIMENSION MAY BE LEFT FOR MACHINING OF EACH FINISHED SURFACE OR WHEEL MAY BE FURNISHED FINISHED TO EXACT DIMENSION SHOWN. HUB LENGTH TOLERANCE IS BASED ON FINISHED DIMENSION.

* REFERENCE GROOVE REQUIRED—SEE RP-619

** HUB WALL THICKNESS MAY BE REDUCED AS NECESSARY FOR APPLICATION OF ROLLER BEARING WATER GUARD.

Fig. B.10 Standard wheel types for locomotive service
Paragraphs 2.1, 15.1, and 15.2

AAR Manual of Standards and Recommended Practices Wheels and Axles

M-107/M-208

APPENDIX B

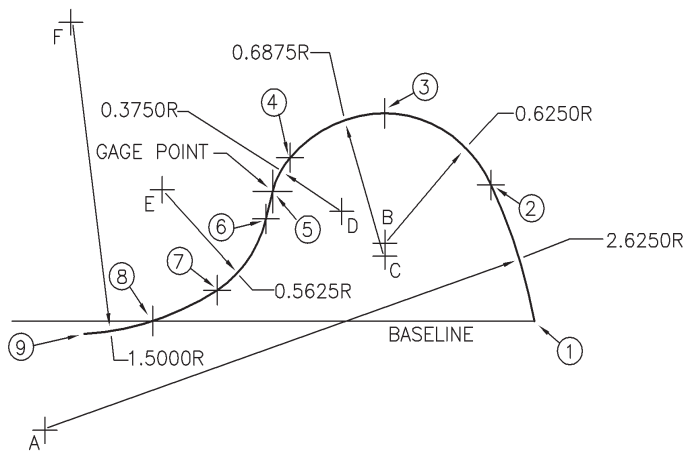
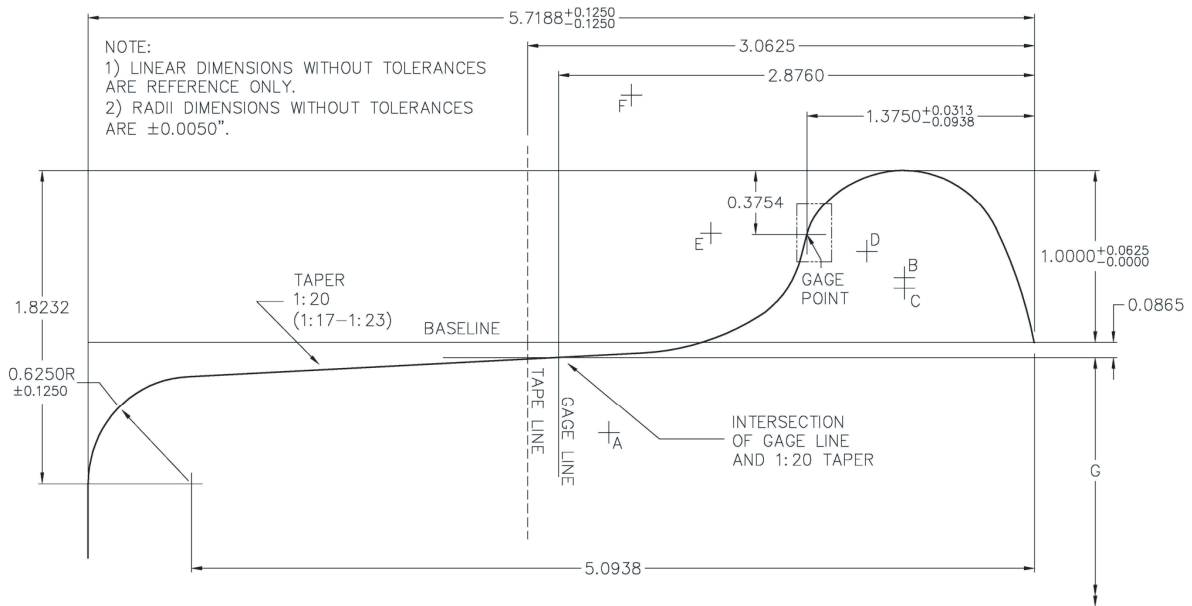

AAR-1B WIDE PROFILE CENTERS OF RADII RELATIVE TO GAUGE POINT

POINT	X	Y
A	-1.196896	-1.149921
B	0.589000	-0.249600
C	0.589000	-0.312100
D	0.362211	-0.097100
E	-0.580300	0.007500
F	-1.060300	0.812800

AAR-1B WIDE PROFILE INTERSECTION OF POINTS RELATIVE TO GAUGE POINT

POINT	X	Y
1	1.375000	-0.624585
2	1.147435	0.031070
3	0.589000	0.375400
4	0.091706	0.162616
5	0.000000	0.000000
6	-0.035442	-0.132273
7	-0.291159	-0.474998
8	-0.631437	-0.624585
9	-0.989517	-0.685529

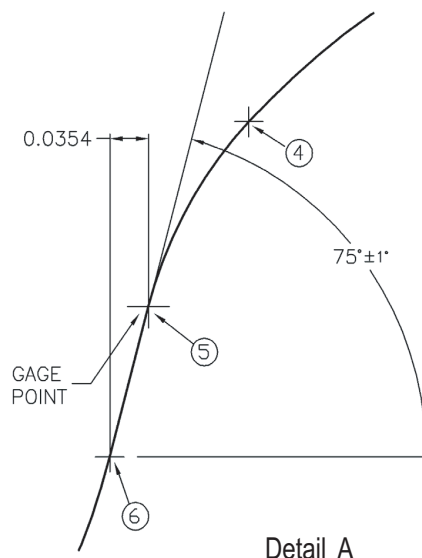

**Fig. B.11 AAR-1B wide-flange contour for freight car wheels
Paragraphs 2.1, 15.1, and 16.2**

AAR Manual of Standards and Recommended Practices

Wheels and Axles

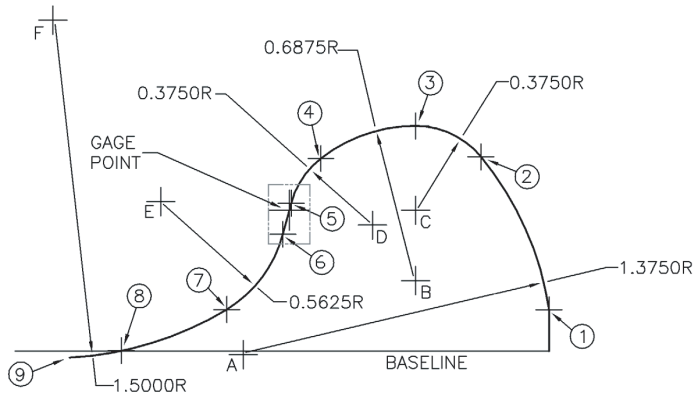
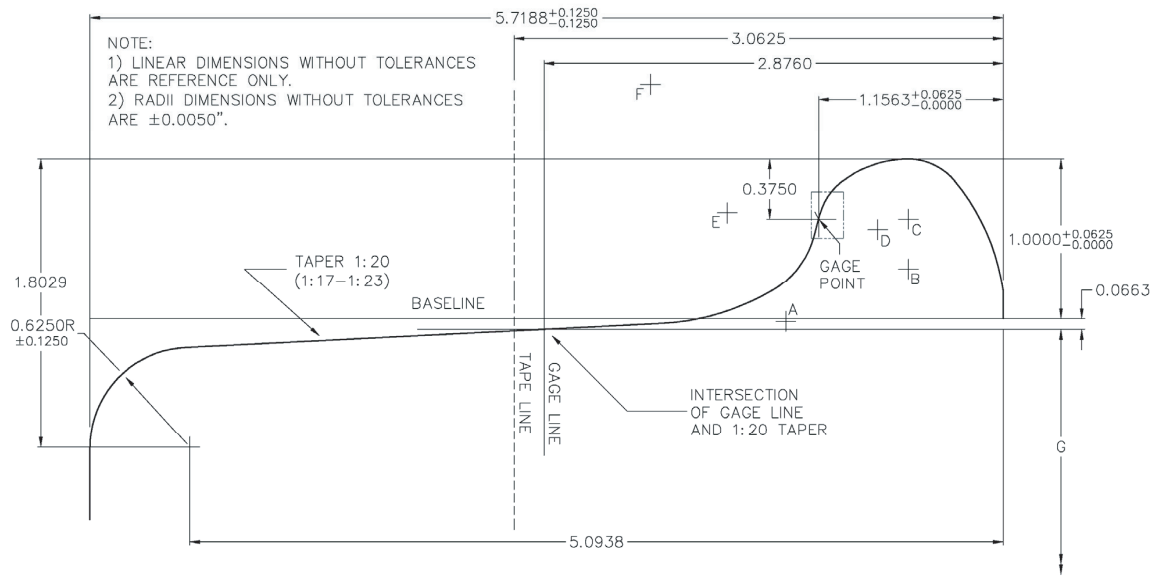

AAR-1B NARROW PROFILE CENTERS OF RADII RELATIVE TO GAUGE POINT

POINT	X	Y
A	-0.204400	-0.641800
B	0.562500	-0.312500
C	0.562500	0.000000
D	0.370581	-0.065876
E	-0.571971	0.038692
F	-1.052000	0.844000

AAR-1B NARROW PROFILE INTERSECTION OF POINTS RELATIVE TO GAUGE POINT

POINT	X	Y
1	1.156300	-444011
2	0.853075	0.237046
3	0.562500	0.375000
4	0.140565	0.230296
5	0.008400	0.031335
6	-0.028575	-0.106659
7	-0.278542	-0.441210
8	-0.748621	-0.625000
9	-0.977100	-0.654129

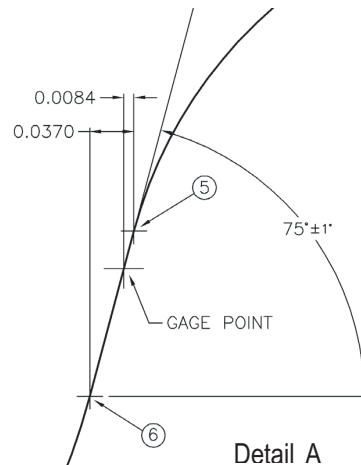
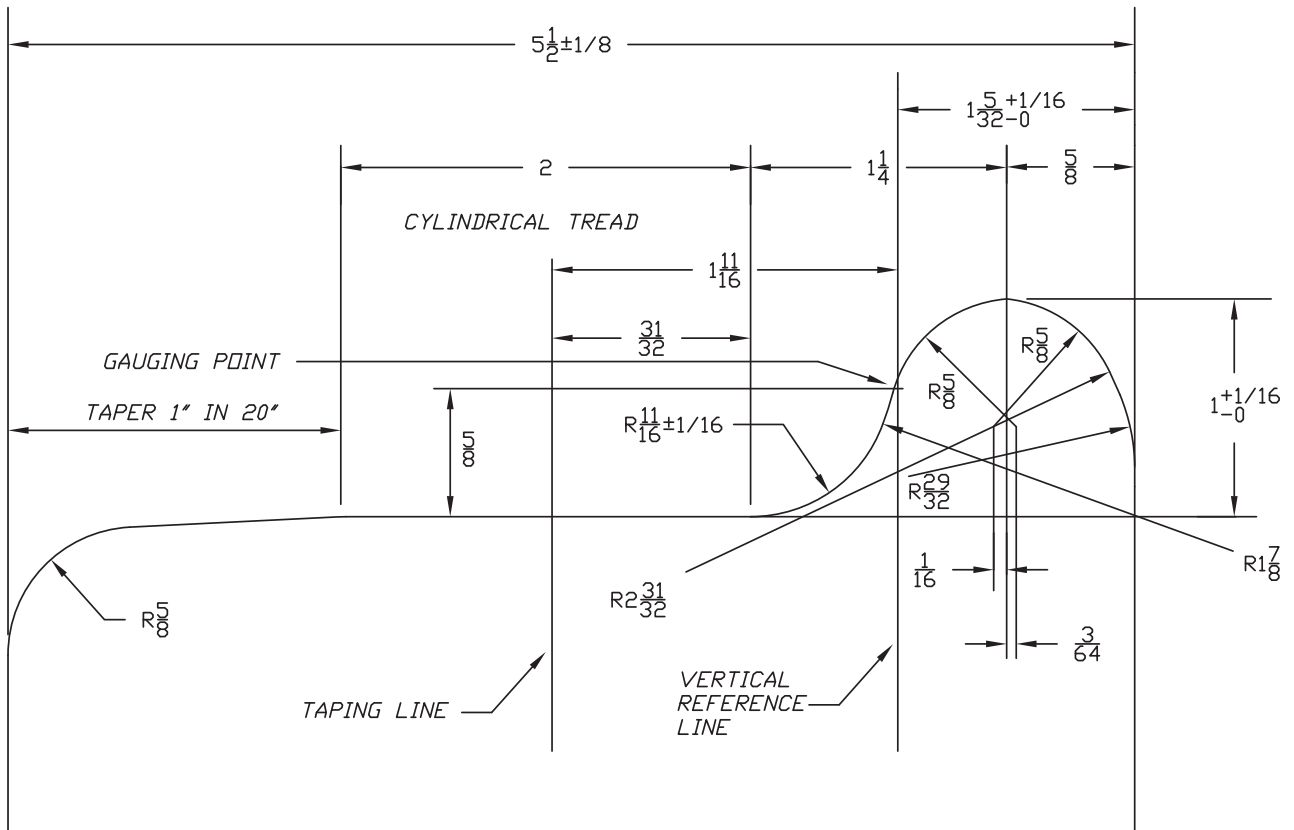

Fig. B.12 AAR-1B narrow-flange contour for freight car wheels
 Paragraphs 2.1, 15.1, and 16.2

AAR Manual of Standards and Recommended Practices
Wheels and Axles

M-107/M-208

APPENDIX B



NOTE: WHEN WHEEL RIMS ARE REDUCED IN THICKNESS TO SUCH AN EXTENT THAT LATHE DOGS INTERFERE WITH THE 5/8-IN. RADIUS AT THE OUTER RIM FACE, THIS RADIUS MAY BE REDUCED AS NECESSARY OR A CHAMFER USED. FREIGHT LOCOMOTIVE WHEEL RIMS SHALL BE MACHINED WITH A MAXIMUM RADIUS OF 5/8 IN. ON THE OUTER RIM FACE. A CHAMFER IS ALLOWED TO EXTEND PAST THE RADIUS AT 45°, BUT MUST BE NO LONGER THAN 0.4375 IN. MEASURED ALONG ITS LENGTH.

Fig. B.13 Cylindrical tread contour for narrow-flange wheels
Paragraphs 2.1 and 16.2

**AAR Manual of Standards and Recommended Practices
Wheels and Axles**

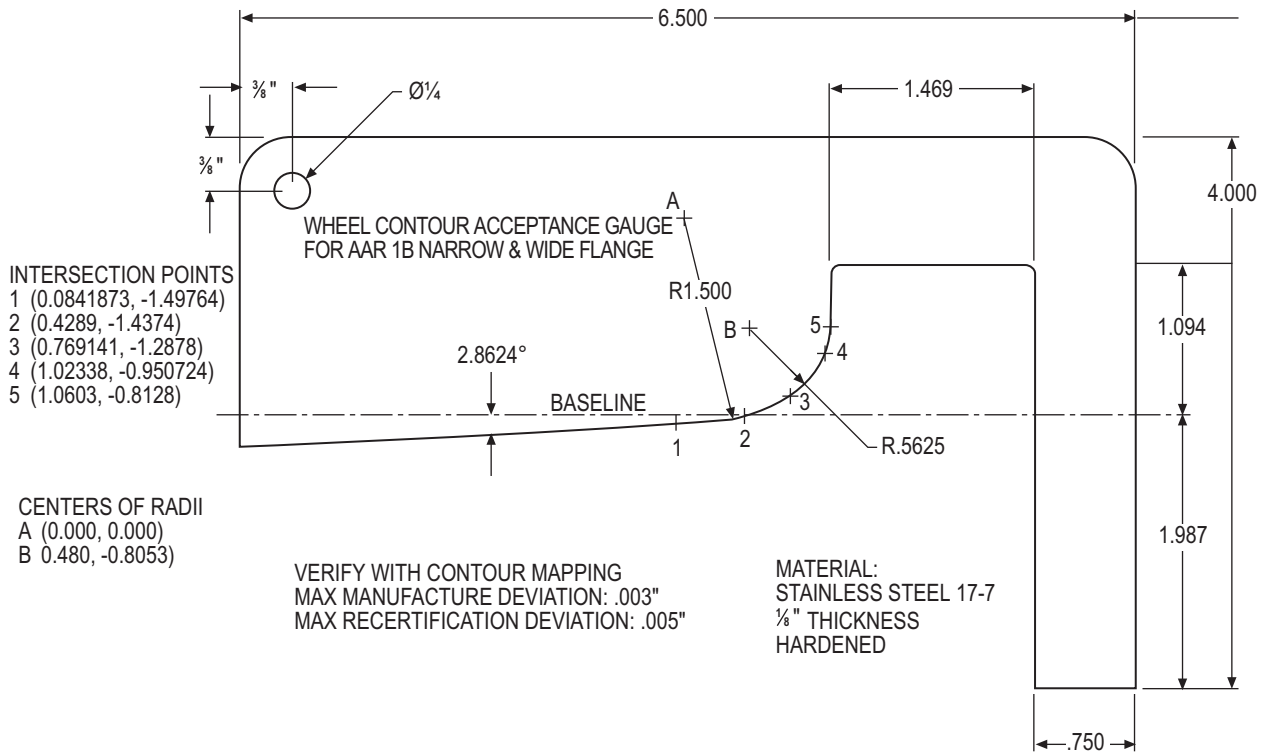

**Fig. B.14 Tread contour gauge for AAR-1B wheels
Paragraph 16.5**

**APPENDIX C
AUTHORIZATION FOR CLASS D WHEEL TEST ALLOTMENT**

1.0 Each manufacturer must obtain an authorization for Class D test wheels from the Committee prior to delivery. All requirements of the M-107/M-208 wheel specification and associated appendixes apply to Class D wheels.

1.1 The intent of Class D is to provide wheel materials with superior resistance to tread damage when compared to Class C wheels, without compromising any other safety performance characteristics.

2.0 Class D wheel applicants must submit results from laboratory material tests as described in paragraph 3.0 of this appendix, "Material Testing." Upon acceptance of the laboratory test results, the WABL Committee will authorize a test allotment of 5,000 wheels for field service testing in interchange service.

3.0 MATERIAL TESTING

3.1 The following material testing is required. The applicant must contact the WABL Committee to schedule an AAR observer. Three sample wheels must be tested. Unless otherwise approved by WABL, an AAR observer is required. All costs for the tests and the observer are to be paid by the applicant. Wheel materials should meet the minimum properties listed in Table 3.1.

3.1.1 Tension testing shall be conducted on two specimens at ambient temperature and two specimens at 1,000 °F. Specimens shall be taken from as close to the tread as possible (at least 1/8 in. of the original wheel tread must remain visible at the ends of the test specimen) in the circumferential direction. Ultimate tensile strength, 0.2% offset yield strength, percentage elongation, and percentage reduction of area shall be determined. Tests must be conducted per ASTM E21 (1,000 °F) and ASTM A370 (ambient temperature), latest edition.

3.1.2 The microstructure shall be classified in the report and should be free of martensite. Six microstructural specimens (1/2 in.² section) shall be taken in the radial plane direction adjacent to the microcleanliness specimens and must include the tread surface. The intent is to classify all microstructures in the specimen, to include the tread surface. The report should contain sufficient photographic evidence to support the conclusions.

3.1.3 Absence of tensile hoop stress shall be documented by a radial saw cut made to a depth at least 1 in. deeper than the rim inner diameter. No opening of the cut shall be present at the conclusion of the cut.

3.1.4 Hardness mapping of the test wheels shall be performed per M-107/M-208, Section 11.5. In addition, Brinell hardness measurements shall also be taken along the centerline of the plate to the hub inner diameter at approximately 1/2 in. spacing and reported for reference only.

AAR Manual of Standards and Recommended Practices

Wheels and Axles

3.1.5 Fracture toughness type testing shall be determined for two samples per test wheel at 70 °F to 75 °F according to ASTM E 399, latest edition. The sample shall be taken as shown in Fig. 3.1. If a valid K_{Ic} is not obtained, then report the K_Q value.

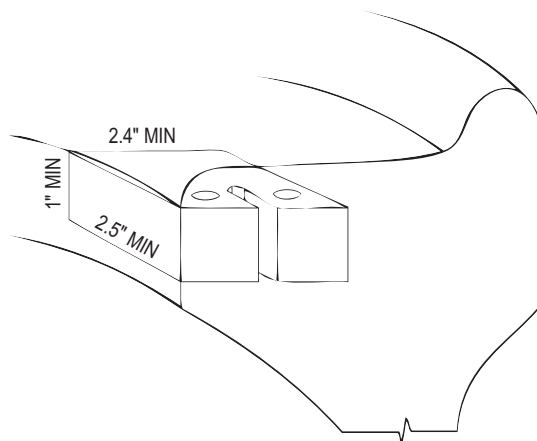

Fig. 3.1 Fracture toughness test sample

3.1.6 The manufacturer must provide lab data demonstrating the relative wear and shelling performance as compared to Class C. The manufacturer must specify the test methods used for the comparison. The following test conditions are recommended. Testing protocols may be changed if better methods can be demonstrated.

3.1.6.1 To demonstrate performance no worse than Class C, comparative accelerated rolling load wear tests shall be conducted. Tests shall be performed using two discs constructed of the proposed wheel material.

3.1.6.1.1 Test conditions shall be as follows:

- Contact pressure = 319,500 psi
- 0.75% slip
- Duration = 500,000 cycles

3.1.6.1.2 The result must be calculated wear rates for Classes C and D.

3.1.6.2 To demonstrate performance superior to Class C, an accelerated rolling load shelling test shall be conducted using two discs.

3.1.6.2.1 Test conditions shall be as follows:

- Contact pressure = 159,750
- 0.3% slip
- Duration = onset of shelling as determined using a vibration sensor

3.1.6.2.2 The result must compare cycles to shelling onset for Classes C and D.

Table 3.1 Minimum material properties

	Ambient (65 °F–80 °F)	1,000 °F
Hardness	341 HB–415 HB	NA
UTS (psi)	>157,000	>70,000
Yield (psi) (0.2% offset method)	>110,000	>50,000
% Elongation in 2 in.	>14	>20
Reduction of Area (%)	>15	>40
Fracture toughness (K_{Ic} or K_Q)	>35 ksi sq root in.	

4.0 FIELD SERVICE TEST ALLOTMENT

4.1 Upon Committee review of the laboratory test program, an allotment of 5,000 wheels shall be granted. The manufacturer shall inspect all wheels in service and report to the Committee the cause for any removals. Manufacturer shall select a service that is expected to accumulate at least 50,000 miles per year.

5.0 FIELD SERVICE TESTING

5.1 It is the responsibility of the manufacturer to monitor the performance of the test wheels in service and report results to the WABL Committee. Reduction of removals for tread damage (as compared to Class C) must be demonstrated. The field service test shall include the following:

- Monitoring a minimum of 1,000 wheels in 286k service
- Documenting car numbers and location of all test wheels
- 100% tracking—for removal causes
- Visual inspections and sample wear monitoring (30% of test wheels) at the following intervals:
 - At least 25,000 miles
 - At least 50,000 miles
 - At least 100,000 miles
 - At least 300,000 miles
 - 400,000 miles

5.2 The field service report shall include the following:

- Removal causes
- Reduction of tread defect removals compared to Class C in the same service
- Percentage of test wheels remaining in service after 300,000 miles

6.0 ADDITIONAL ALLOTMENTS

6.1 A second test allotment of 5,000 wheels may be applied for after the 300,000-mile report.

6.2 After the 400,000-mile test report is accepted by the WABL Committee, additional allotments may be approved per Appendix A.

**AAR Manual of Standards and Recommended Practices
Wheels and Axles**

THIS PAGE LEFT BLANK INTENTIONALLY